



8593 State Highway 77
P.O. Drawer K
Oran MO 63771 USA
Toll free : 1 800 545-5086
T.: 573 262-2166



SIDE DUMP OPERATOR MANUAL

TABLE OF CONTENTS

GENERAL INFORMATION	3
PRODUCT DISCLAIMER	4
INTRODUCTION	4
SEMI-TRAILER INFORMATION	5
TO THE OWNER	7
SAFETY	8
CUSTOMER CHECKLISTS.....	14
DAILY CHECKLISTS.....	18
PUNCTUAL CHECKLISTS	19
WHEEL INSPECTION.....	20
WHEEL INSPECTION DURING TIRE INSPECTION	21
WHEEL REINSTALLATION AND NUT TIGHTENING	22
AXLE INSPECTION.....	24
COUPLING AND UNCOUPLING.....	25
OPERATING INSTRUCTIONS	31
HYDRAULIC.....	34
TRACTOR HYDRAULIC SYSTEMS.....	34
ADJUSTMENT AND OPERATION OF BRAKES	35
TIRES.....	36
SPRING SUSPENSION / AIR SUSPENSION.....	37
LANDING GEAR OPERATION GUIDELINES.....	40
ELECTRICAL SYSTEM	41
TORQUE REQUIREMENTS.....	43
DECALS/REFLECTORS	45
APPENDIX I: DECALS/REFLECTORS.....	48
APPENDIX II: TROUBLESHOOTING	56
APPENDIX III: CONNECTOR WIRING CHANGE	59

GENERAL INFORMATION

Manac requires that for safe, efficient and trouble-free operation of a Side Dump Semi-trailer, you and anyone else who will be operating, repairing or maintaining such semi-trailer should read this manual and all labels on the trailer carefully and understand the safety, operation, maintenance and troubleshooting information contained within this Operator Manual. If you have difficulty following the directions or aren't sure you can safely and properly follow these instructions, call Manac at 1 800-361-7900 or visit www.manac.com. Failure to read and follow the manual could lead to serious injuries, death or costly repairs.

Keep an electronic copy or a hard copy of this manual near at hand while operating the semi-trailer for easy access and reference. If assistance, information, or additional copies of the manual are needed, contact the nearest dealer, a distributor or Manac. You can also view the most recent version of this manual on Manac's website at www.manac.com.

All references to roadside, curbside, front and rear of the semi-trailer are determined from a position behind the semi-trailer and facing forward, as shown in the following figure.

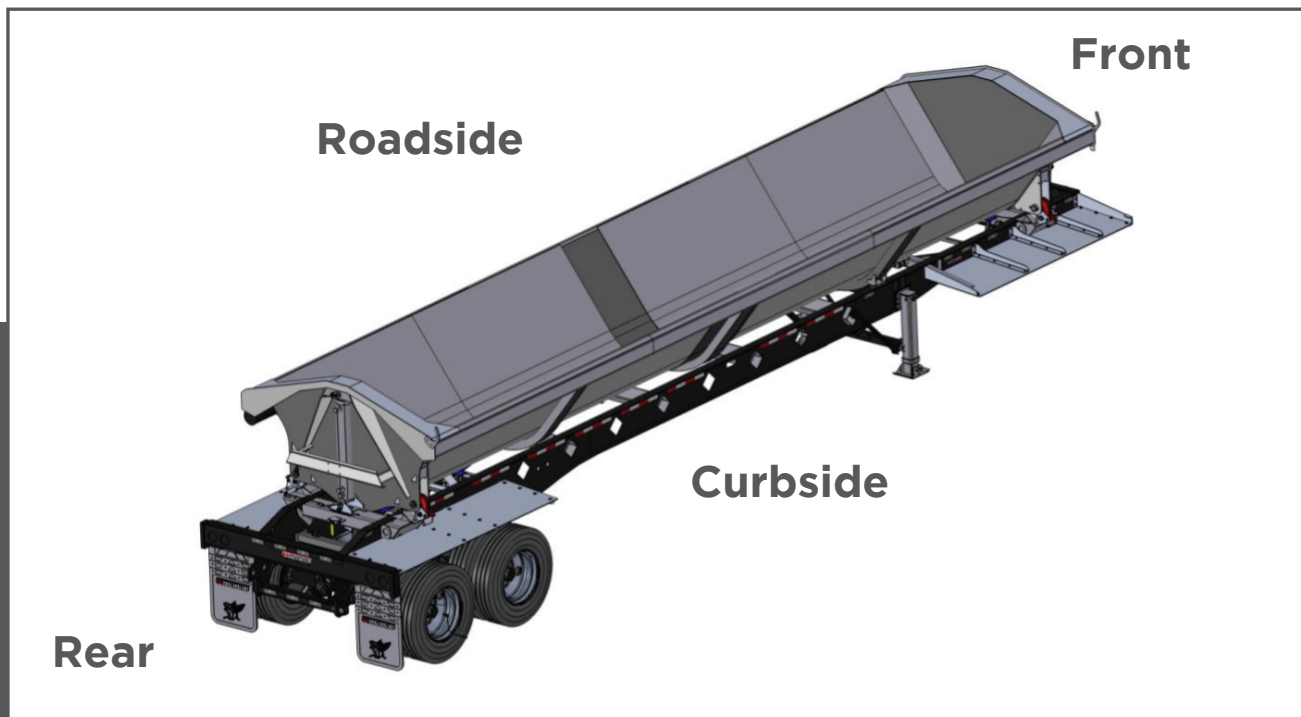

Figure 1

PRODUCT DISCLAIMER

This document provides a general description of the proper procedures and instructions which must be considered before starting operations with, and during maintenance of all Manac Side Dump Semi-Trailer models. Although the information in this manual was current on the date of issue (2025), Manac reserves the right to make changes as needed without notice or liability. You can view the most recent version of this manual on Manac's website at www.manac.com.

No self-modification or unauthorized modification or alteration should be made to this semi-trailer as it may affect its operation, function and safety. We encourage owners to source and purchase replacement parts for Manac products directly from Manac. Please contact Manac at 1 800 545-5086 for further information on replacement parts and components and nearest dealers and repair shops.

INTRODUCTION

Manac is the largest manufacturer of semi-trailers in Canada and a leader in the manufacturing of specialty semi-trailers in North America. Manac offers a wide range of van bodies, flatbeds and specialty semi-trailers such as dumps, low-beds, grain hoppers, chassis, belt trailers, chip and logging semi-trailers, all of which are sold in Canada and the United States namely under the recognized brands Manac®, CPS®, Peerless™, Darkwing®, UltraPlate®, Ultravan®, Liddell Canada™, Cobra™, Alutrec® and ABS™. Manac services the heavy-duty semi-trailer industry for the highway transportation, construction, energy, mining, forestry and agricultural sectors and manufactures its semi-trailers in facilities located in Saint-Georges, Laurier-Station and Val-des-Sources (Quebec), Penticton (British Columbia) as well as Oran (Missouri, USA).

This manual contains information covering all models of the Manac Side Dump Semi-Trailer line. The table of contents should be used to locate specific areas of interest.

SEMI-TRAILER INFORMATION

VEHICLE IDENTIFICATION NUMBER (VIN)

Location of the vehicle identification number is shown in the following figure:

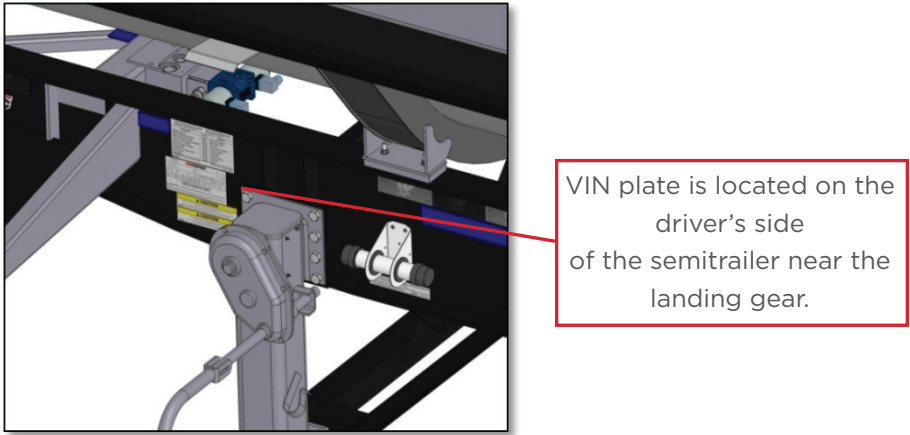
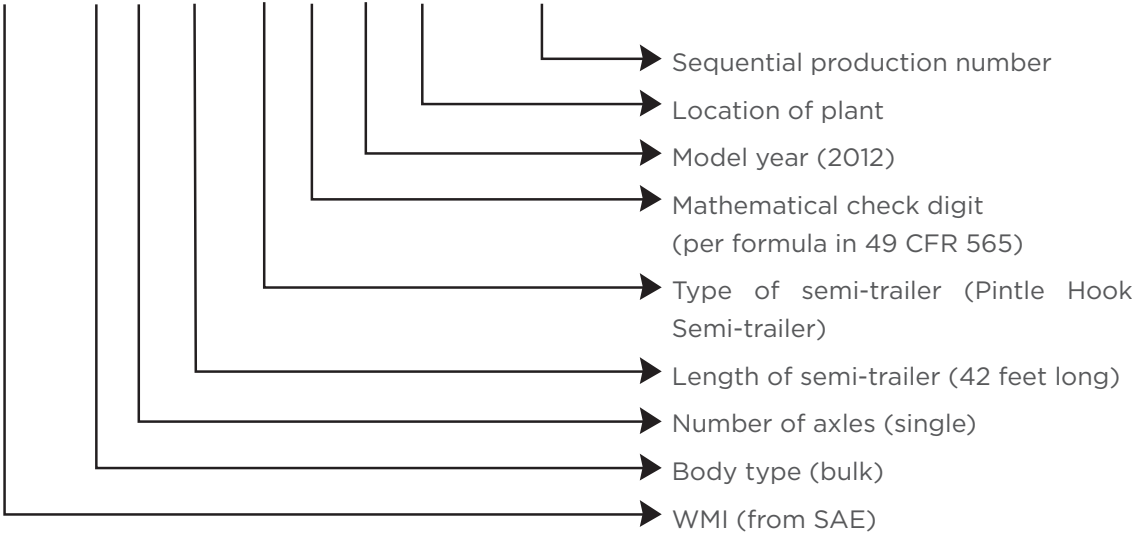

Figure 2

5MC-3-1-42-2-6-C-P-013847



To provide prompt and efficient service while ordering parts, your dealer needs the information below on your semi-trailer model and VIN number.

MODEL NO. _____
VIN NO. _____
IN SERVICE DATE _____

SEMI-TRAILER INFORMATION

This Manac semi-trailer was designed for operation within legal road speed limits on reasonable road surfaces for the type of service it was built to perform.

This semi-trailer was built to carry cargo within the limitations of weight ratings shown on the certification/identification plate (see example below as Figure 3). These ratings are as follows:

GAWR (Gross Axle Weight Rating): The GAWR is the structural capability of the lowest-rated member of the running gear components: suspension and spring system, hubs, wheels and drums, rims, bearings, brakes, axles or tires.

GVWR (Gross Vehicle Weight Rating): The GVWR is the structural capability of the semi-trailer when supported by the kingpin and axles with the load uniformly distributed throughout the cargo space.

MANUFACTURED BY: FABRIQUÉ PAR: MANAC TRAILERS USA INC. AU/IN USA				DATE: 08/2011				
GVWR PNBV	77000 LB	34927 KG	MODEL	SGH42				
AXLES ESSIEUX	GAWR PNBE		TIRES PNEUS	RIMS JANTES	COLD INFL. PRESSURE PRESS. GONFL. À FROID		DUAL JUMELÉS	SINGLE SIMPLE
	LB	KG			PSI	KPA		
FRONT	21000	9525	11R24 5 (G)	24.5X8.25	100	689	X	
REAR	21000	9525	11R24 5 (G)	24.5X8.25	100	689	X	
V.I.N.	5MC314226CP013847							
TYPE TRA/REM								
THIS VEHICLE CONFORMS TO ALL APPLICABLE US FEDERAL MOTOR VEHICLE SAFETY STANDARDS IN EFFECT ON THE DATE OF MANUFACTURE SHOWN ABOVE.								
THIS VEHICLE CONFORMS TO ALL APPLICABLE STANDARDS PRESCRIBED UNDER THE CANADIAN MOTOR VEHICLE SAFETY REGULATIONS IN EFFECT ON THE DATE OF MANUFACTURE/ CE VÉHICULE EST CONFORME À TOUTES LES NORMES QUI LUI SONT APPLICABLES EN VERTU DU RÉGLEMENT SUR LA SÉCURITÉ DES VÉHICULES AUTOMOBILES DU CANADA EN VIGUEUR À LA DATE DE SA FABRICATION*								

Figure 3

This semi-trailer will carry a total payload of the Gross Vehicle Weight Rating (GVWR) minus the weight of the semi-trailer. You can find the semi-trailer's weight on the certification/identification plate.

The cargo should be properly loaded and blocked to prevent load shifts and to comply with the existing regulations of the North American Cargo Securement Harmonization Program. For more information, you may consult www.cvsa.org.

CAUTION: The maximum load indicated on the certification/identification plate may or may not be a legal load on the highway or road you plan to use. **It is the responsibility of the owner and/or operator to ensure compliance with road regulations.**

TO THE OWNER

Congratulations and thank you for choosing a Manac Side Dump Semi-Trailer. Manac is committed to building and providing you with the highest quality product.

This manual has been prepared to assist you in retaining the safety, dependability and performance that are built into Manac semi-trailers. It is essential that this Side Dump Semi-Trailer receives periodic inspections, maintenance and service as well as appropriate parts replacement.

This manual includes safety checks that the operator should periodically perform as well as instructions and procedures that the operator must comply with in order to operate the semi-trailer safely. It is important that every Side Dump Semi-Trailer owner and/or operator has an organized Trailer Preventive Maintenance (TPM) program. The United States' and Canada's Departments of Transportation require by law that the maintenance records be kept on every commercial highway vehicle. It is to your advantage to be able to show that regularly scheduled TPM inspection checks have been made on every piece of equipment operated and it will ensure that you get the most out of your Manac Side Dump Semi-Trailer.

Read this manual carefully. Should you have any questions, contact your Manac representative or dealer immediately. Keep an electronic copy or a hard copy of this manual near at hand while operating the semi-trailer and transfer it to the buyer if you sell a semi-trailer.

FOR WARRANTY INFORMATION

REFER TO THE WEBSITE:

[HTTPS://WWW.MANAC.COM/US/EN/TRAILERS/CPS-STEEL-SIDE-DUMP](https://www.manac.com/us/en/trailers/cps-steel-side-dump)

SAFETY



**THIS SYMBOL MEANS:
ATTENTION!
BE ALERT!
YOUR SAFETY IS
INVOLVED!**

FAILURE TO FOLLOW THESE INSTRUCTIONS CAN RESULT IN INJURY OR DEATH!

SIGNAL WORDS

Please take note of the use of the signal words **DANGER**, **WARNING** and **CAUTION** with safety messages in this manual and in safety decals affixed on the semi-trailer. These decals are designed using safety words, symbols, and a color code. It is essential to understand the impact of the color code and the content of the decals before operating the semi-trailer or undertaking any repair work on it.

The appropriate signal word for each safety message has been selected using the following guidelines:

DANGER

The word “danger” is used in the most hazardous situations, which, if not avoided, will result in serious injury or death.

WARNING

The word “warning” is used when there is a hazardous situation that could result in serious injury or death if proper precautions are not taken.

CAUTION

The word “caution” is used for potential hazards or dangerous situations that, if not avoided, may result in minor or moderate injury. It is used to emphasize caution. If the word “caution” is used without the alert symbol, it may be used as a notice (e.g., to inform of a potential equipment failure).

NOTICE

The word “notice” is used for information where there is no risk of personal injury. It can be used for safety instructions, to indicate a risk of material damage, but also for information that is not safety related.

SAFETY

⚠ WARNING

IDENTIFY AND FOLLOW SAFETY INSTRUCTIONS

- When you see the safety alert symbol on your semi-trailer or in this manual, be alert to the potential for personal injury and material damage. Follow recommended precautions and safe operating practices.
- Replace any caution, warning, danger or instruction safety decal that is damaged, missing or not readable. Location of such decals is indicated in the Decals/Reflectors section of this manual. Contact Manac at <http://parts.manac.com> to obtain replacement decals free of charge.
- Learn how to operate the tractor and semi-trailer and how to use the controls properly.
- Do not let anyone operate the tractor and/or semi-trailer without reading this manual first.
- Keep your tractor and semi-trailer in proper working condition at all times.

⚠ WARNING

TRAVEL SAFETY

- Only trained and licensed commercial drivers should operate this semi-trailer.
- Make sure the vehicle you are operating and the load you are carrying are in compliance with all local regulations regarding transporting on public roads and highways. Consult your local law enforcement agency for further details.
- Always know the weight of the semi-trailer plus any cargo before operating the semi-trailer. Do not exceed the GAWR (Gross Axle Weight Rating) or the GVWR (Gross Vehicle Weight Rating).
- Make sure all the lights and reflectors that are required by the local road, highway and transport authorities are in place, are clean and can be seen clearly by all overtaking and oncoming traffic.
- Always drive at a safe speed relative to local conditions and ensure that your speed is low enough for an emergency stop to be safe and secure.
- Drive carefully and defensively at all times and especially when negotiating uneven or hilly terrain.
- Do not drive while impaired (alcohol, drugs, fatigue, etc.).
- Be a safe and courteous driver. Yield to oncoming traffic in all situations, including narrow bridges, intersections, etc.
- Be observant of bridge load ratings. Do not cross bridges rated lower than the gross weight at which you are operating.
- Always operate the semi-trailer in a position to provide maximum visibility at all times. Make allowances for increased length and weight of the equipment when making turns, stopping the semi-trailer, etc.

SAFETY

⚠️ WARNING

HYDRAULIC SAFETY

This semi-trailer utilizes a hydraulic system to power its two hydraulic cylinders. The hydraulic cylinders are used to raise and dump the tub, to return the tub in the normal position and to adjust the dump and return speeds.

- Escaping fluid under pressure can penetrate the skin causing serious injury.
- Release pressure on the system before doing any maintenance.
- Wear proper hand and eye protection when searching for a high-pressure hydraulic leak. Do not use your hands to isolate or identify a leak.
- If injured by a concentrated high-pressure stream of hydraulic fluid, seek medical attention immediately. Serious infection or toxic reaction can develop from hydraulic fluid piercing the skin surface.
- Before applying pressure on the system, make sure all components are tight and that lines, hoses and couplings are not damaged.
- Improperly disposing of fluids can harm the environment and ecology. Before draining any fluids, contact your local environmental agency for the proper waste disposal methods.
- Use proper containers when draining fluids. Do not use food or beverage containers that may mislead someone into drinking from them.
- DO NOT pour oil into the ground, down a drain, or into a stream, pond or lake. Observe relevant environmental protection regulations before disposing of oil and other harmful waste.

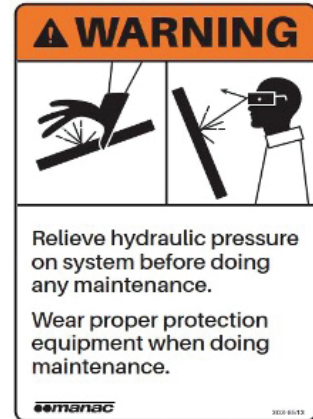

⚠️ WARNING

OPERATING SAFETY

- Do not operate the semi-trailer unless all inspections set forth in the Customer Checklist section of the manual have been conducted.
- Do not modify the semi-trailer in any way. Doing so may impair the operation, function and/or safety and could affect the life of the semi-trailer.
- Do not paint over, remove, cover, mask or deface any safety signs or warning decals on your semi-trailer.
- Observe all safety signs, read all decals and follow the instructions on them.
- Do not operate the semi-trailer with any brake defects or with brakes out of adjustment.
- Clear the area of all vehicles, objects of any kind and bystanders, especially children, before starting up and operating the tractor and semi-trailer.
- Maintain kingpin, fifth wheel assembly and all running gear in good condition at all times.
- Do not operate the semi-trailer with parking brakes caged or in any other way disabled.
- Never climb into the semi-trailer body. Use extreme caution when climbing on ladders, steps and catwalks. Always maintain 3-point contact when climbing on and off the semi-trailer.



SAFETY

⚠ DANGER

MAINTENANCE SAFETY

Always refer to this manual for proper safety procedures to prevent tub body lowering before proceeding with maintenance. Clear area from vehicles, objects and bystanders of any kind before raising the tub.

- Place all controls in neutral, stop the tractor engine, remove ignition key and set the park brake before adjusting, servicing or maintaining any part of the semi-trailer.
- Never attempt to open a spring brake chamber. Spring brakes must be caged or deactivated before servicing.
- Maintain fasteners at their specified torque at all times.

⚠ DANGER

Only trained or certified technicians should conduct maintenance on this semi-trailer.

⚠ DANGER

To prevent serious injury or death from pinching, exhaust air from the system prior to maintenance. Keep clear of pinch points.

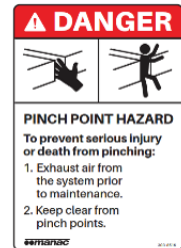

HYDRAULIC SYSTEMS

The semi-trailer should be hooked to the tractor on a level surface when fully empty, and the hydraulic hoses should be uncoupled before performing maintenance between the frame rails. If service required, go to a service center equipped with the proper tooling and facilities for such a repair.

TUB AND FRAME INSPECTIONS

The structural integrity of the chassis and the tub is essential. The visual inspection of these must be done systematically before each use.

- Check welds for cracks or breakage.
- Check for bent or deformed parts.
- Check for parts abnormally damaged by rust.
- Check for unusually loose parts.

BREAK-IN PROCEDURE

After the first 24 hours of use of the semi-trailer, perform the following maintenance procedures:

- Readjust torque on all suspension bolts and axle U-bolts. Torque specifications are shown on decals located on the semi-trailer subframe and in the Torque Requirements section of this manual.
- Readjust torque on all wheel lug nuts.
- Check all clearance lights, turn signal indicators and stop lights.
- Inspect all brake hoses and airlines for kinks and leaks.
- Check hub oilers for leaks or low levels.
- Inspect hydraulic lines and valves for leakage, chafing or crimped lines.

SAFETY

⚠ DANGER

DUMPING SAFETY

To avoid injury or semi-trailer damage during dumping:

- Close, lock and secure the pivot lock with the pin through the bracket.
- Make sure that the locks on the opposite side of the dumping area are open.
- Make sure that the semi-trailer is levelled with the ground before dumping. Do not attempt to dump load on uneven or unstable ground.
- Tractor and semi-trailer wheels must be in a straight line.
- Make sure that there are no overhead hazards or power lines.
- Clear the area around the semi-trailer from vehicles, objects and bystanders of any kind before attempting to dump.
- Air suspension must be fully charged while dumping.
- Stand clear of tub body and load.
- Operator must remain at the controls until cylinders are fully retracted.
- Do not stop cylinder extension at any point during the extension cycle.



⚠ WARNING

LOAD DISTRIBUTION SAFETY

The total weight of the load you put on the semi-trailer, plus the empty weight of the semi-trailer itself, must not exceed the semi-trailer's Gross Vehicle Weight Rating (GVWR). You must distribute the load on the semi-trailer so that the load on any tire or axle does not exceed the tire load rating or the Gross Axle Weight Rating (GAWR). If you do not know the weight of your semi-trailer, you must weigh it at a commercial scale. See your VIN plate for proper ratings. See the Semi-Trailer Information section of this manual for more details. Failure to follow these guidelines could cause serious injury or death.

⚠ DANGER

TIRE AND LUG NUT SAFETY

- Failure to follow proper procedures when mounting a tire on a wheel or rim can result in an explosion which may cause serious injury or death.
- Do not attempt to mount a tire unless you have the proper equipment and qualifications to do so.
- If you do not have the proper equipment and experience, have a qualified tire dealer or repair service center perform the required tire maintenance.
- Replace the tire before towing if the tire has a bald spot, cut, bulge, is showing any cords, or is cracked.
- If uneven tread is noticed, take the semi-trailer to a service center for an inspection. Tire imbalance, axle misalignment, or incorrect inflation could cause the uneven tread.
- Too little of tread could be inadequate for traction and can cause loss of control on wet roads.

SAFETY

- Improper tire pressure causes an unstable semi-trailer and could blow out a tire, causing a loss of control.
- Check the tire pressure before towing, while the tire is cold. For the recommended pressure, see the VIN plate or the side wall of the tire.
- Always order and install tires and wheels with the appropriate type and load capacity for at least the gross weight of the semi-trailer.
- When towing a new semi-trailer, check the lug nuts after the first 50 to 100 miles of driving.
- Metal creep between the wheel and the lug nuts will cause the wheel to loosen and possibly come off. Check to make sure the lug nuts are tight before each tow.
- Improper torque could cause the wheel to separate from the semi-trailer. A torque wrench should be used to tighten the lugs nuts. If one is not available, use a lug wrench then go to a semi-trailer dealer or service garage to tighten the lug nuts to the required torque.

REPORTING SAFETY DEFECTS

If you believe that your semi-trailer has a safety defect, you should contact the manufacturer, the National Highway Traffic Safety Administration (NHTSA) or both.

This Side Dump Semi-Trailer was designed to comply with the industry standards and all applicable NHTSA safety standards. Manac warrants this semi-trailer vehicle to be free from defects in materials and workmanship when manufactured.

If you believe that your semi-trailer has a defect which could cause a crash, injury or death, you must immediately inform the NHTSA in addition to notifying Manac.

If the NHTSA receives other similar complaints, it may open an investigation, and if it finds that a safety defect exists in a group of semi-trailers, it may order a recall and remedy campaign. However, the NHTSA cannot become involved in individual problems between you and your dealer or Manac.

To contact the NHTSA, you may call the Vehicle Safety Hotline, toll-free, at 1 (800) 424-9393 (or 202-366-0123) in Washington, D.C. area or write to: NHTSA, U.S. Department of Transportation, Washington, D.C.20590. You can also find out more about motor vehicle safety at

<http://www.safercar.gov>

You may contact Manac at :

8593 State Highway 77, P.O. Drawer K

Oran MO 63771 USA

Toll free: 1 800 545-5086 • T. : 573 262-2166

CUSTOMER CHECKLISTS

This section contains safety checklists you must conduct in order to ensure safe operation of the semi-trailer. The appropriate timeline or frequency is indicated for each set of inspections.

If the semi-trailer or any of the associated equipment does not pass these inspections, do not use the semi-trailer until the issue has been fixed. Failure to follow these instructions can result in property damage, serious injury and death.

NEW TRAILER DELIVERY CHECK

The following checklist contains the items to inspect upon receipt of your semi-trailer.

1. Retighten wheel nuts

- All nuts on each wheel must be torqued between 450 and 500 ft-lbs.

2. Check the oil level of the oil caps

- All wheels.

3. Check the condition of the tires (without puncture)

Note: If tires are inflated, recheck after 24 hours.

4. Check the condition and function of the pneumatic system

- Check for free play of the brakes.
- Check the brake chamber stroke.
- Check the position of the air springs.
- Look for leaks.
- Make 3 brake applications.

5. Check the condition and operation of the electrical system

- Check lights, electrical wires and ABS.

6. Check the functioning of moving parts

- Check vertical supports, hinges and locks.

7. Visually inspect the interior of the unit

8. Visually inspect the outside of the unit

- Check for scratches or bumps.

9. Check the clamping of the undercarriage bolts

- Check air tanks, shocks and air springs.

CUSTOMER CHECKLISTS

PRE-TRIP (trailer checklist only)

Pre-trip inspections are common practice throughout North America. However, the related requirements and procedures may differ from one region, state or country to another. Refer to the applicable standard practice in your region of operation.

The following pre-trip checklist outlines some of the main items to inspect on the semi-trailer and may not include all items required in your region or state of operation and doesn't include items to inspect on the truck. Use it as a practical guideline but always refer to the applicable practice of your region or state of operation.

⚠️WARNING

Most pre-trip inspections are visual. Check electrical wiring, brake hoses and other brake components, look for distorted or broken structural components and welds. Report all defects to the proper people before deciding to start your trip.

PERFORM THE PRE-TRIP CHECKLIST WHENEVER THE TRACTOR AND SEMI-TRAILER HAVE BEEN LEFT UNATTENDED.

1. Air and Electrical Connections

- Glad hand is properly mounted, free of damage, not leaking and not worn.
- Electrical line receptacle is properly mounted and free of damage, plug adequately seated and safety catch engaged to prevent accidental disconnection.
- Hydraulic couplers are properly seated and tightened, there are no leaks and they are properly secured against tangling, snagging and chafing, with sufficient slack for turning.
- Air, electrical and hydraulic lines are properly secured to avoid tangling, snagging and chafing with sufficient slack for turns.

2. Lights and Reflectors

- Semi-trailer clearance and identification lights should be clean, operating and of adequate color.
- Stops lights, turn signals and tail lights must be fully operational.
- Reflectors and reflective tape are clean and of adequate color.

3. Hydraulic Cylinder

- There are no oil leaks.

4. Fifth Wheel

- Is securely mounted to frame.
- There are no missing or damaged parts.
- There is no visible space between upper and lower fifth wheel.
- Locking jaws are around the shank and not around the head of the kingpin.
- Check the locking indicator at the front and on the side of the fifth wheel.

CUSTOMER CHECKLISTS

- Release lever while properly seated and with safety latch lock engaged.
- Make sure the kingpin is not worn, bent or damaged.
- Make sure the anchor frame is not cracked, bent, worn or damaged.

5. Landing Gear

- Is fully raised and secured, there are no missing parts or bent or otherwise damaged parts.
- Crank handle is present and secured (typically on left side).

6. Brakes

- Check the condition of hoses, lines and valves.
- Check proper adjustment of slack adjusters.
- Check that brake chamber push rods have proper stroke.
- Check spring brakes.
- Check that parking brake is effective.
- Check parking brake release.
- Check working order of parking brake light.
- Drain moisture from air tank with cable.

7. Tires

- Check tire condition.

8. Wheels

- Check wheel condition.
- Check lugs and wheel retainers and look for missing ones.

9. Suspension

- On the leaf spring suspension, check condition of leaf springs.
- On the air suspension, check the level of the semi-trailer.
- On the air suspension, listen for noises from the suspension supply lines.

10. Frame

- Check the condition of the main frame rails and crossmembers.

CUSTOMER CHECKLISTS

PRE-TRIP CIRCLE CHECK (suggested)

FRONT

- Head lights
- Clearance lights
- Identification lights
- Turn signals and 4-way flasher
- Tires and wheels (lugs)

ON COMBINATIONS

- Hoses and couplers
- Electrical connector
- Couplings (fifth wheel, kingpin)
- Hydraulic cylinder, couplers, and hoses

ON VEHICLES TRANSPORTING HAZARDOUS MATERIALS

- Marking or placards
- Proper shipping papers

LEFT SIDE

- Fuel tank and cap
- Landing gear
- Side marker lights
- Reflectors
- Tires and wheels (lugs)
- Suspensions
- Frame rails

REAR

- Tail lights
- Stop lights
- Turn signals and four-way flasher
- Clearance lights
- Identification lights
- Reflectors
- Tires and wheels (lugs)
- Rear end protections (bumper)
- Hydraulic cylinder, couplers, and hoses

RIGHT SIDE

- Fuel tank and cap
- Side marker lights
- Reflectors
- Tires and wheels (lugs)
- Suspensions
- Frame rails
- Landing gear

DAILY INSPECTION CHECKLIST

Perform the Daily Inspection Checklist once a day before operating your semi-trailer.

1. PERFORM THE PRE-TRIP CHECKLIST

2. CHECK THAT:

- There are no sharp bends or pinched lines in any of the air lines and hydraulic hoses.
- Lights operate properly.
- Fifth wheel plate is greased.
- All hubs are checked for proper oil level.
- All hubs are checked for loose lug nuts.
- All cylinder pins are greased.
- All tub pivots are greased.
- Cam shafts are greased.
- Landing gear is greased.

3. TUB AND FRAME INSPECTION:

The structural integrity of both the chassis and the tub is essential. The visual inspection of these must be done systematically before each use.

- Check welds for cracks or breakage.
- Check for bent or deformed parts.
- Check for parts abnormally damaged by rust.
- Check for unusually loose parts.

Any defect detected must be repaired before using the semi-trailer.

PUNCTUAL CHECKLIST

The following checklists must be performed at the mileage or period indicated, unless the owner/operator suspects non-compliance, failure or damage prior to such mileage or period. The appropriate remedy must then always be taken immediately.

Checks to be performed on the semi-trailer for every 10,000 miles or yearly, whichever comes first:

WHEEL NUT TIGHTENING TORQUE

1. Check that wheel nuts are tightened to a final torque between 450 and 500 ft-lbs. Refer to the Wheel Reinstallation and Tightening Procedure of this manual.

⚠WARNING

A drop of torque may result in damage or loss of wheels.
Recheck torque every 10,000 miles.

Checks to be performed on the semi-trailer for every 25,000 to 50,000 miles or yearly, whichever comes first:

HYDRAULIC PRESSURE SYSTEM

As the hydraulic pressure systems of these semi-trailers are totally dependent upon the hydraulic system of the towing vehicle for its oil supply, pressure and control, the hydraulic pressure system of the towing vehicle must be in good condition with steady clean oil supply in order to have the proper dumping performance with the semi-trailer.

Hydraulic oil filter should be replaced every 25,000 miles or yearly, whichever comes first.

The entire hydraulic system should be drained and flushed every 50,000 miles with pressure and flow rates checked.

WHEEL INSPECTION

1. While making the tire inspections, check all metal surfaces thoroughly, including areas between duals and on the inboard side of the wheel.

Check for:

- Uncontrolled rust or corrosion build-up.
- Cracks and flaws in metals.
- Bent flanges, resulting from road obstructions.
- Deep rim tool marks on rings or in gutter areas.
- Loose, missing or damaged nuts or clamps.
- Bent or stripped studs.
- Cracked or missing rim drive plates.
- Mismatched rim parts.
- Unaligned wheels.

2. Replace damaged rims or wheels.

⚠ CAUTION

Uncontrolled corroded or damaged rims or rings can be dangerous. Deflate tires prior to the removal of rims or wheels from the semi-trailer.

3. Point out damaged or hazardous areas with paint so that the damaged parts can be replaced.

4. Replace damaged parts and check that replacements are made with the proper sizes and types of rims and rings.

5. Inflate tires only to recommended air pressures.

⚠ DANGER

Do not use the semi-trailer if there is any damage to the tires or wheels. Failure to follow these instructions can result in property damage, serious injury and death.

WHEEL INSPECTION DURING TIRE INSPECTION

TROUBLESHOOTING WHEEL PROBLEMS

Cracks in the wheel disc, between stud holes or hand holes are caused by loose wheel nuts, improper installation procedures, overloading and/or use of incorrect sizes or types of attaching parts.

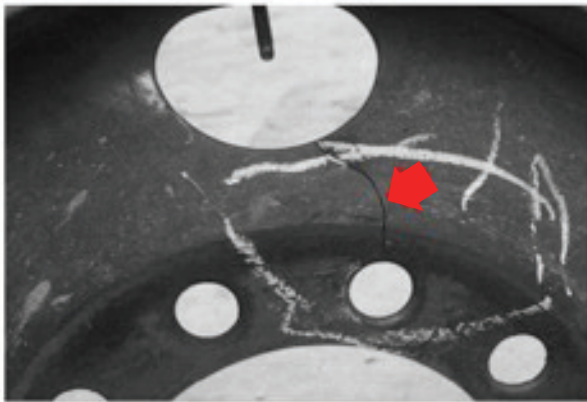

Figure 4

PROBLEM: WHEEL DISC CRACKS

- Hand hole to hand hole
- Hand hole to stud hole
- Hand hole to rim

CAUSE: OVERLOADING

REMEDY:

- Check actual load on axle.
- Install new wheel according to load requirements.

PROBLEM: WHEEL DISC CRACKS

- Stud hole to stud hole

CAUSE: LOOSE WHEEL NUTS INSUFFICIENT BACKUP DIAMETER

REMEDY:

- Check for worn mating face on hub or drum.
- Check for loose studs in hub.
- Check for cracked or broken studs.
- Replace any damaged parts.
- Follow proper torque procedures described.

Cracks through side ring, spreading laterally through the entire section (not shown) are caused by improper mounting and dismounting techniques, impact with road obstructions and excessive clamping torque.

A sprung side ring is caused by improper mounting procedures. Erosion and chipping of bead seat of lock ring are caused by excessive corrosion. This may occur with this part as well as others if protective measures are not taken.

WHEEL REINSTALLATION AND NUT TIGHTENING

Check all parts for damage, including wheels and ring clamp. Ensure that studs, nuts and mounting faces of hubs and wheels are clean and free of grease. Replace any defective parts.

Mount single wheel or inner dual wheel (also, outer dual wheel for hub type mounting) over studs, being careful not to damage stud thread. Draw up nuts alternately to 50 ft-lbs into the sequence shown, but do not tighten them fully. This procedure will allow the uniform seating of nuts and ensure the even face-to-face contact of wheels and hub.

Tighten nuts fully to a final torque between 450 and 500 ft-lbs (oiled), using the same alternate sequence. Use a torque wrench tool to achieve proper torque value. Mount the outer wheel (for double cap mounting) and repeat the entire procedure. In each case, be sure to tighten wheel nuts only to the torque level recommended in the table below and to maintain them at that level through planned, periodic checks.

⚠ WARNING

Rim nuts should be checked for proper torque after the vehicle has been operated for 50 to 100 miles, and every 2,000 to 10,000 miles thereafter, as well as during regular maintenance checks. Do not intermix wheel types. Insufficient mounting torque can cause wheel shimmy, resulting in damage to parts and extreme tire tread wear which can result in serious injury or death. Excessive mounting torque can cause studs to break and discs to crack in the stud hole area.

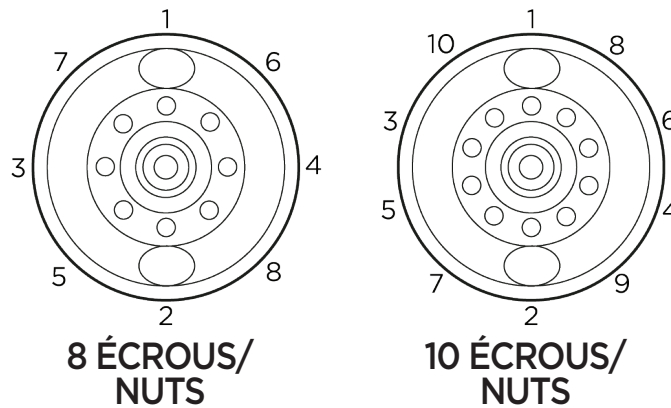

Figure 5

WHEEL REINSTALLATION AND NUT TIGHTENING

LUBRICATION OF FLANGE NUTS AND STUDS

To assure proper tension when torquing the flange nuts, it is necessary to renew the lubricant on the threads and between the nut and the flange. Relubrication should be done each time the wheels are removed for service.

1. Apply 2 drops of lubricant on the threads of the stud. Also apply 2 drops between the nut and its flange.
2. Any commonly available lubricant will do: engine oil, WD-40, anti-seize compounds, etc.
3. Take special care not to lubricate any of the following surfaces: the surface between the hub and the brake drum, brake drum and wheel, both wheels and the surface between the outer wheel and the flange nut face.
4. An excess of lubricant will not enhance performance. It will only make parts harder to handle and attract dirt.

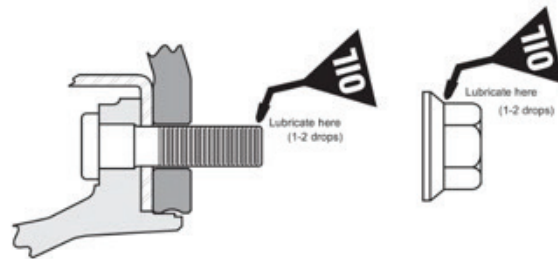

Figure 6

AXLE INSPECTION

OIL LUBRICATED WHEEL BEARING

Check hub gaskets and seals for oil leaks prior to each trip. A leaking seal can result in ruined wheel bearings and possible failure of the axle-wheel assembly.

Check the oil level in hubs prior to every trip. Add oil when level is low, only to the level indicated by the mark on the hub cap. Too much oil can damage the wheel bearings. Use synthetic oil grade 50 (transmission), or an equivalent mineral oil-based product.

OIL LEVEL LINE

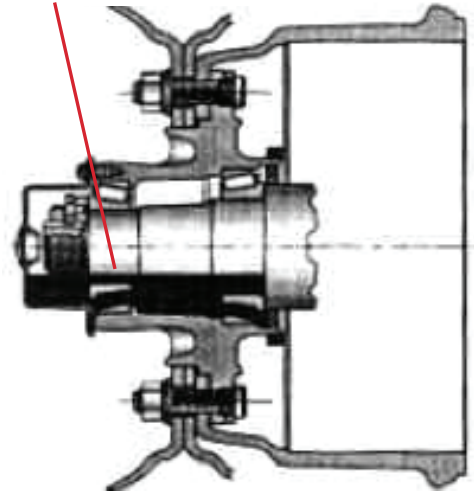

Figure 7

GREASE OR SEMI-FLUID GREASE WHEEL BEARING

Inspect, as a minimum, during service, the inner side of the hub for obvious leakage. Correct leakage problem if occurring. Also, it is necessary to ensure, at every 50,000 miles, that the outer bearing is getting lubricated and that there is enough grease in the hub. This is especially important with the wheel-end systems using the smaller outer bearing. A visual inspection through the inspection plug or after removing the hubcap should be made. If inadequate grease is suspected (obvious lack of grease) pull the outer bearing to ensure a sufficient amount of grease. Replenish if necessary. If there is any sign of overheating or component damage, the wheel-end system should be redone.

GREASE LEVEL LINE

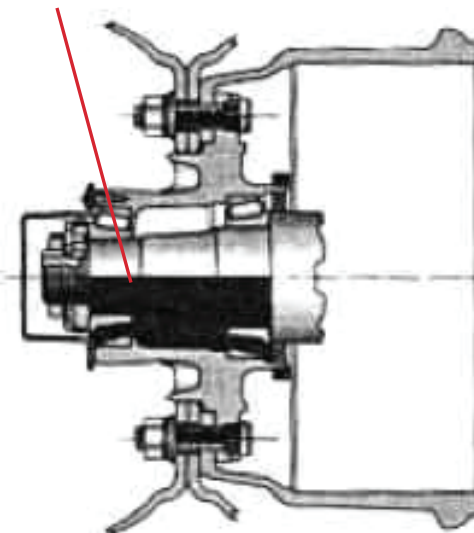

Figure 8

AXLE ALIGNMENT

Axle alignment must be checked at regular intervals. If the semi-trailer is not tracking properly, this should be corrected shortly to avoid tire uneven wear and/or components accelerate wear.

COUPLING AND UNCOUPLING

Knowing how to couple and uncouple the semi-trailer correctly is fundamental to safe operation of your semi-trailer. General coupling and uncoupling steps are listed below. Learn the details of coupling and uncoupling for the tractor you will operate.

COUPLING A TRACTOR WITH THE SEMI-TRAILER

Step 1: Inspect Fifth Wheel

- Check for damaged/missing parts on both the tractor and the semi-trailer.
- Check to see that mounting to the tractor is secure, there are no cracks in the frame, etc. Be sure that the fifth wheel plate is greased as required. Failure to keep the fifth wheel plate lubricated could cause steering problems due to friction between the tractor and the semi-trailer.
- Check if fifth wheel is in proper position for coupling:
 - Wheel tilted down towards rear of the tractor.
 - Jaws opened.
 - Lock handle in the automatic lock position.
- If you have a sliding fifth wheel, make sure it is locked.
- Make sure the semi-trailer kingpin is not damaged or worn.

Step 2: Inspect Area and Chock Wheels

- Always use chock blocks or lock the semi-trailer brakes when uncoupling or coupling tractor and semi-trailer on the road or in the terminal area. Chock as required for unusual conditions.
- Make sure the area around the tractor and semi-trailer is clear of vehicles, objects of any kind and bystanders.
- Make sure the semi-trailer parking brakes are applied.
- Check that cargo (if any) is secured against movement caused by the tractor being coupled to the semi-trailer.

Step 3: Position Tractor

- Back the tractor directly in front of the semi-trailer. Never back under the semi-trailer at an angle, because you might push the semi-trailer sideways and damage the support legs.
- Using outside mirrors, check position by looking down both sides of the semi-trailer. Make sure the tractor and the semi-trailer are on stable and even ground.

Step 4: Back Slowly

- Back until fifth wheel just touches the semi-trailer.
- Do not hit the semi-trailer.

Step 5: Secure Tractor

- Put on the parking brake.
- Put transmission in neutral.

COUPLING AND UNCOUPLING

⚠ CAUTION

It is important, before coupling your Manac semi-trailer, to check that the fifth wheel coupling height is compatible with the semi-trailer coupling height. Too high or too low fifth wheel coupling height may result in premature weariness of tires, brakes, bearings, etc. In addition, too high coupling height may result to an overall dimension higher than 13'6".

SAMPLE:



Step 6: Check Semi-trailer Coupler Height

- The semi-trailer should be low enough so that it is raised slightly by the tractor when the tractor is backed under it. Raise or lower the semi-trailer as needed. (If semi-trailer is too low, the tractor may strike and damage nose of the semi-trailer; if semi-trailer is too high, **it may not couple correctly.**)
- Check that the kingpin and fifth wheel are aligned.

Step 7: Connect Air Lines to Semi-trailer

- Check glad hand seals and connect tractor supply (emergency) air line to the semi-trailer supply (emergency) glad hand.
- Check glad hand seals and connect tractor control (service) air line to the semi-trailer control (service) glad hand.
- Make sure air lines are safely supported and cannot be crushed or caught while tractor is backing under the semi-trailer.

Step 8: Supply Air to Semi-trailer

- From the tractor cab, press the "Air Supply" knob or move tractor protection control valve from the "Emergency" to the "Normal" position to supply air to the semi-trailer brake system.
- Wait until the air pressure is normal.
- Check brake system for crossed air lines:
 - Shut engine off so you can hear leaks in the brake system.
 - Apply and release semi-trailer brakes. Listen for sound of semi-trailer brakes being applied and released. You should hear the brakes move when applied and air escape when the brakes are released.
 - Check air brake system pressure gauge for signs of major air loss.
- When you are sure the semi-trailer brakes are working, start the tractor engine.
- Make sure air pressure is normal.

COUPLING AND UNCOUPLING

Step 9: Lock Semi-trailer Brakes

- Pull out the “Air Supply” knob or move the tractor protection control valve from “Normal” to “Emergency” position.

Step 10: Back Under Semi-trailer

- Use lowest reverse gear.
- Back tractor slowly under semi-trailer to avoid hitting the kingpin too hard.
- Stop when the kingpin is locked into the fifth wheel.

Step 11: Check Connection for Security

- Raise the semi-trailer support legs slightly off the ground.
- Pull tractor gently forward while the semi-trailer brakes are still applied.

Step 12: Connect Hydraulic Couplers to Trailer

- Connect hydraulic lines to the semi-trailer connectors.

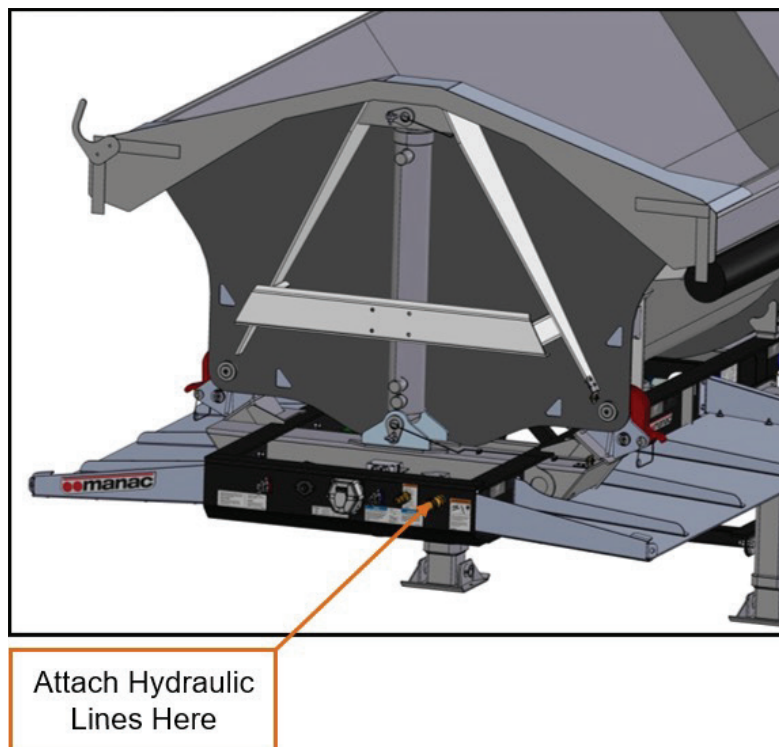

Figure 9

COUPLING AND UNCOUPLING

Step 13: Secure Tractor

- Put transmission in neutral.
- Put parking brakes on.
- Shut off engine and take the key with you so that no one else can move the tractor and/or the semi-trailer while you are under it.

Step 14: Inspect Coupling

- Use a flashlight if necessary.
- Make sure there is no space between the upper coupler and the fifth wheel. If there is space, something is wrong (the kingpin may be on top of closed fifth wheel jaws: the semi-trailer could come loose very easily).
- Go under the semi-trailer and look into the back of the fifth wheel. Make sure the fifth wheel jaw is closed around the shank of the kingpin.
- Check that the locking lever is in “lock” position.
- Check that the safety catch is positioned over the locking lever. (On some fifth wheels, the catch must be put in place manually.)
- If the coupling is not properly secured, do not drive the coupled semi-trailer; get it fixed.

Step 15: Connect the Electrical Cord and Check Air lines

- Plug the electrical cord into the semi-trailer and fasten the safety catch.
- Check air lines and electrical lines for signs of damage. Repair or replace if necessary.
- Make sure air and electrical lines and hydraulic hoses will not hit any moving parts of the tractor or the semi-trailer.

Step 16: Raise Semi-trailer Support Legs (Landing Gear)

- Use low gear range (if so equipped) to begin raising the support legs. Once free of weight, switch to the high gear range.
- Raise the support legs all the way up. Never drive with support legs only part way up as they may catch on railroad tracks or other things.
- After raising the support legs, properly secure the crank handle.
- With the front of the semi-trailer supported by the tractor:
 - Check for enough clearance between rear of tractor frame and support legs. (When tractor turns sharply, it must not hit the support legs or their bracing.)
 - Make sure that there is adequate clearance between the top of the tractor tires and the underside of the semi-trailer.

COUPLING AND UNCOUPLING

UNCOUPLING A TRACTOR FROM A SEMI-TRAILER

Step 1: Position Rig

- Make sure the surface of the parking area can support weight of the semi-trailer and that the ground is stable and even.
- Place tractor in a straight line with the semi-trailer.
(Pulling out at an angle can damage the support legs.)

Step 2: Ease Pressure on Locking Jaws

- Shut off semi-trailer air supply to lock semi-trailer brakes.
- Ease pressure on fifth wheel locking jaws by backing up gently (this will help you release the fifth wheel locking lever).
- Put parking brakes on while tractor is pushing against the kingpin. This will hold the rig with pressure off the locking jaws.

Step 3: Lower the Support Legs

- Lower the support legs until they make firm contact with the ground. Turn crank in low gear a few extra turns to lift some weight off the tractor. (Do not lift the semi-trailer off the fifth wheel.)
This will:
 - Make it easier to unlatch fifth wheel.
 - Make it easier to couple next time.

Step 4: Disconnect Air Lines and Electrical Cable

- Disconnect air lines from the semi-trailer. Connect air lines glad hands to dummy couplers at back of cab, or couple them together.
- Hang electrical cable with plug down to prevent moisture from entering it.
- Make sure lines are supported so they will not be damaged while the tractor is moving.

Step 5: Unlock Fifth Wheel

- Raise release handle lock.
- Pull the release handle to “open” position.

⚠ WARNING

Keep legs and feet clear of the rear tractor wheels, to avoid serious injury in case the tractor moves and make sure the area is clear of vehicles, objects and bystanders of any kind.

Step 6: Pull Tractor Partially Clear of Semi-trailer

- Pull tractor forward until fifth wheel comes out from under the semi-trailer.
- Stop with tractor frame under the semi-trailer (this prevents the semi-trailer from falling to ground if support legs should collapse or sink).

COUPLING AND UNCOUPLING

Step 7: Secure Tractor

- Apply parking brakes.
- Place transmission in neutral.

Step 8: Inspect Semi-trailer Support

- Make sure the ground is supporting the semi-trailer.
- Make sure the support legs are not damaged.

Step 9: Pull Tractor Clear of Semi-trailer

- Release parking brakes.
- Drive tractor clear of the semi-trailer.

OPERATING INSTRUCTIONS

SETTING THE TUB TO DUMP CURBSIDE OR ROADSIDE

⚠ CAUTION

Before dumping the tub, determine which direction the tub is going to dump when raised. Make sure the latches on each end of the tub are locked in the same direction. Failure to do so will result in damage to the semi-trailer and/or tractor.

CURBSIDE DUMPING:

All steps are performed on the roadside only and the curbside locks must be in locked condition. The steps must be performed on both the front and the rear pivots.

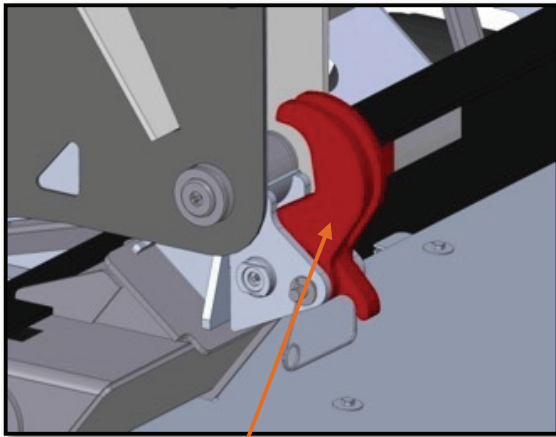

ROADSIDE HOOKS OPEN
Figure 10

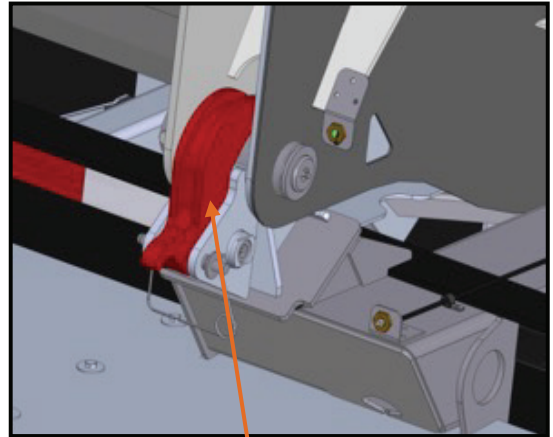

CURBSIDE HOOKS LOCKED
Figure 11

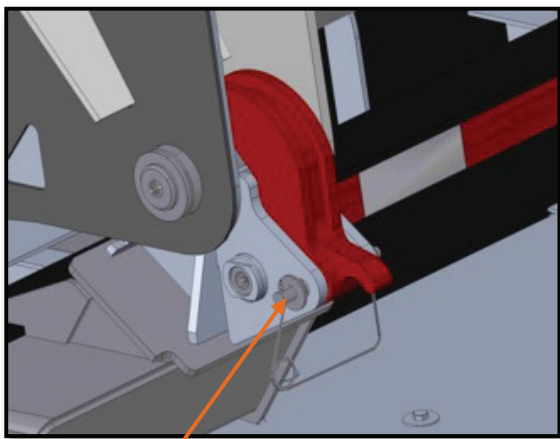

STEP 1:
Pull lock pins out to release pivot lock hook
Figure 12

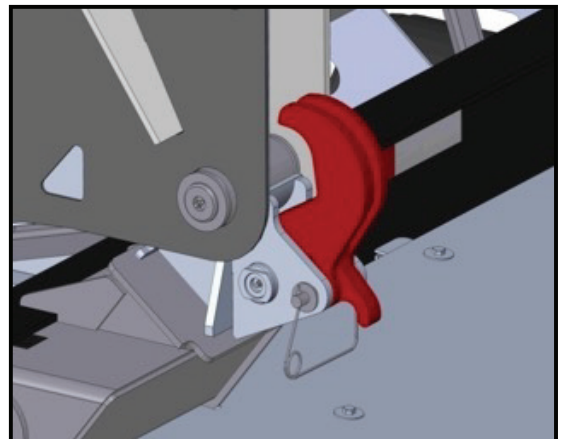

STEP 2:
Pull hook downward to unlock the tub
Figure 13

OPERATING INSTRUCTIONS

ROADSIDE DUMPING:

All steps are performed on the curbside only and the roadside locks must be in locked condition. The steps must be performed on both the front and the rear pivots.

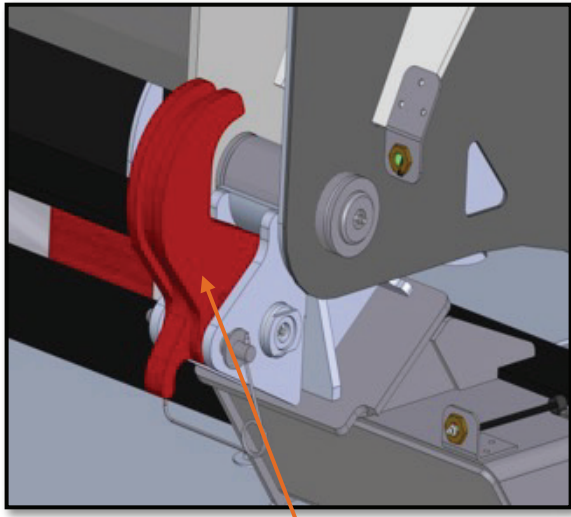

CURBSIDE HOOKS OPEN
Figure 14

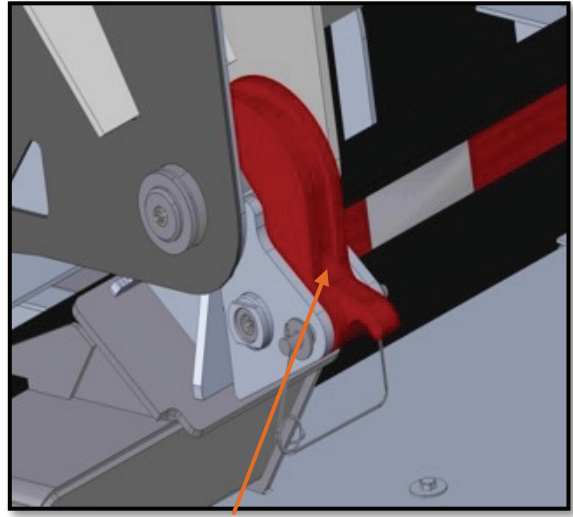

ROADSIDE HOOKS LOCKED
Figure 15

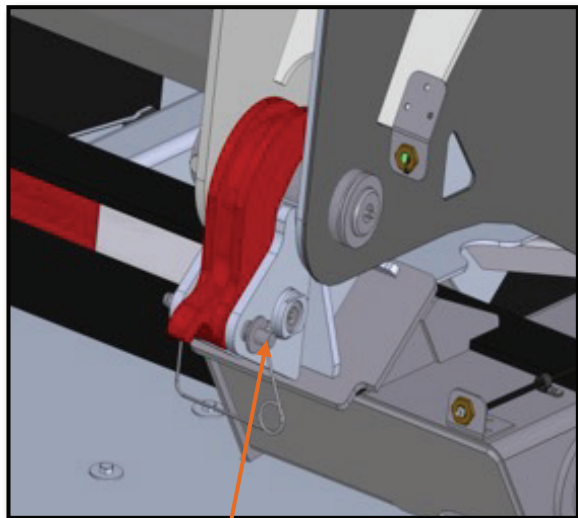

STEP 1:
Pull lock pins out to release pivot lock hook

Figure 16

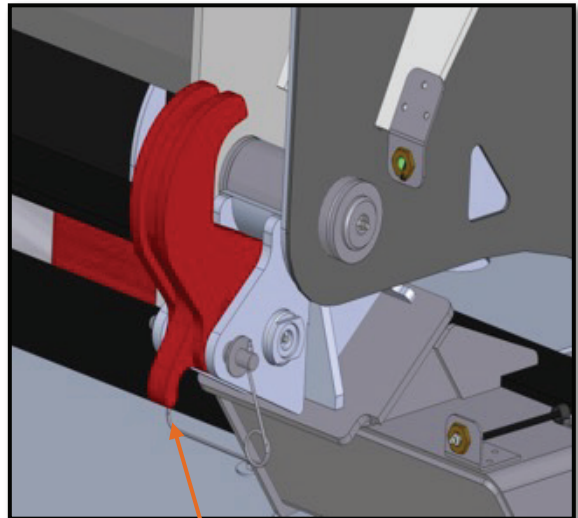

STEP 2:
Pull hook downward to unlock the tub

Figure 17

OPERATING INSTRUCTIONS

FIRST TIME HITCHING OF SEMI-TRAILER



Figure 18

Check complete extending and retracting of cylinders before operation.

⚠ CAUTION

1. Do not attempt to dump load on uneven or unstable ground.
2. Tractor and semi-trailer wheels must be in a straight line.
3. Make sure that there are no overhead hazards or power lines.
4. Clear the area around semi-trailer of vehicles, objects and bystanders of any kind.
5. Air suspension must be fully charged.
6. Do not attempt to dump a frozen or otherwise solidified load.

FILLING AND DUMPING SEMI-TRAILER

Filling:

- Make sure that the tarp is removed.
- Stand clear of the semi-trailer during filling.
- Suspension air bags must be charged when filling.

Dumping:

- Stand clear of the tub body.
- Stand clear of the load and of the dumping area.
- The operator must remain at the controls until cylinders are fully retracted.
- Do not stop cylinder extension at any point during the extension cycle.
- After dumping:
 1. Return the tub to normal position.
 2. Push hooks back to locked position.
 3. Reinsert the lock pin to lock pivot.



Figure 19

HYDRAULIC

Hydraulic schematic is available on our website. For any question, contact your Manac representative, dealer or our after-sales service.

TRACTOR HYDRAULIC SYSTEM

The semi-trailer can operate at top efficiency with high quality, operational safety and long life service if clean lubricants are used and if the tractor's hydraulic system provides clean, high-pressure, high-volume oil supply. Use clean containers to handle all lubricants. Store lubricants in an area protected from dust, moisture and other contaminants.

The hydraulic pump pressure should be set at 2500 PSI with a minimum output of 25 GPM supply and at least a 15-gallon filtered and strained tank.

⚠WARNING

The hydraulic system should only be maintained and fixed by certified technicians.

GENERIC SEMI-TRAILER HYDRAULIC SYSTEM

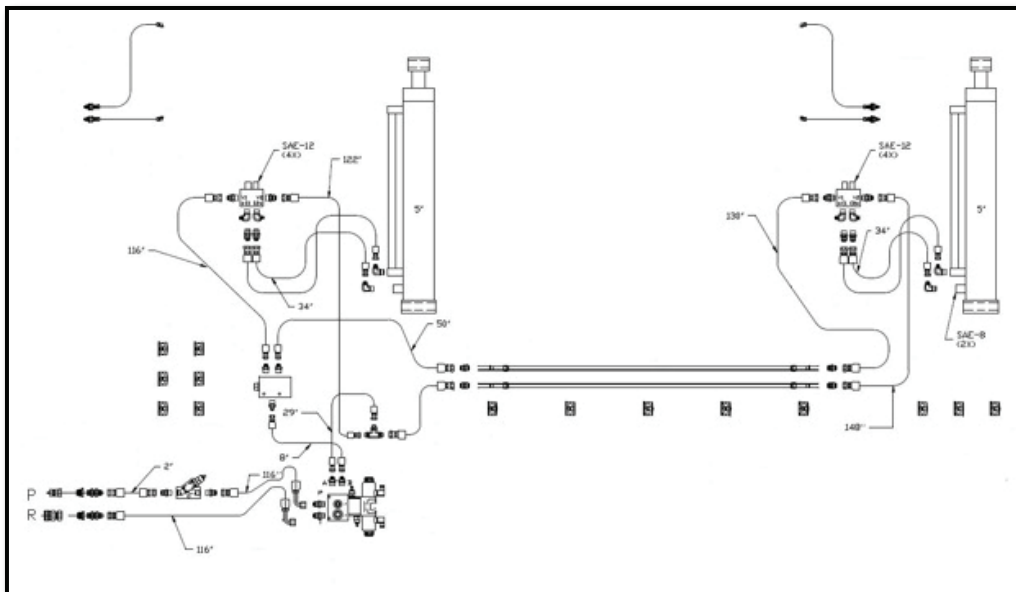

Figure 20

ADJUSTMENT AND OPERATION OF BRAKES

CARE AND ADJUSTMENT OF BRAKES

The semi-trailer brake system will perform safely and efficiently only as long as you service it properly and do not overwork it. Semi-trailer brakes should be inspected and adjusted frequently in connection with a Trailer Preventative Maintenance program.

Non-adjusted brakes can increase stopping distance, shorten brake component life, and lead to a greater tendency for the semi-trailer to jack knife.



Figure 21

AIR SYSTEM AND BRAKE OPERATION

- Inspect the glad hands for seal damage and cracked housings. Inspect the air hoses for cracking and for frayed connections. Replace or repair damaged components.
- Keep the air system clean. Air tanks should be drained daily to remove moisture and other contaminants, especially during cold weather operations.
- Use of additives such as antifreeze in the air brake system is not recommended. It may result in deterioration of valve seals and affect the performance of the brake system.
- Keep the air system tight. The air system cannot be charged properly if there are leaks in tanks, lines, hoses or valves.
- Prior to moving the semi-trailer, run the tractor's engine until the air brake system pressure gauge shows no brakes are applied.
- Do not leave Teflon tape or any other thread sealer in the air system. It could result in clogged valves.

⚠WARNING

Do not operate the semi-trailer with any brake defects or with brakes out of adjustment. Remember that serious air losses create extremely hazardous conditions that might cause accidents or breakdowns.

TIRES

TIRES

- Do not over inflate the tires.
- Check for proper inflation with an accurate gauge when the tires are cold. Check the spare tire(s) too. Never operate a semi-trailer with any tire having incorrect air pressure.
- Inspect tires for nails and other objects embedded in the rubber, and for stones and other objects lodged between duals.
- Examine tires to make sure that they are free of breaks and other defects.
- Examine new and retreaded tires for signs of failure during the break-in period.
- Dual tires on any axle end should have the same diameter.
- Check the depth of the tread.
- Inspect valve stem to detect potential damage.
- Make sure the replacement tires or rims are the same size, type and load rating each time you replace them.

⚠WARNING

Do not use the semi-trailer if there is any damage to any tire. Failure to follow these instructions can result in property damage, serious injury and death.



Figure 22

TIRE LOADS

The total load per tire must not exceed the tire manufacturer's specified load carrying capacity at stated inflation pressures for tires and rims. For your information, Manac has assigned Gross Axle Weight Ratings (GAWR) to each semi-trailer.

The GAWR and tire information shown on the semi-trailer certification plate was applicable at the time the semi-trailer was manufactured. If the tires or other components of the running gear have been changed or altered since the semi-trailer was manufactured, the GAWR may have changed. It is the operator's responsibility to ensure that they have the appropriate information in such case.

(Refer to the Semi-Trailer Information section on page 6.)

SPRING SUSPENSION / AIR SUSPENSION

LEAF SPRING SUSPENSION

Check the equalizer to see that there are no obstructions to movement during operation. If equalizer movement is restricted by an obstruction, the axle “walk” will not be sufficient and damage will result thereof. Check wear pads in hangers. If they are wearing thin, install new wear pads or the spring will cause permanent damage to the hanger itself. Do not operate with broken spring leaves.

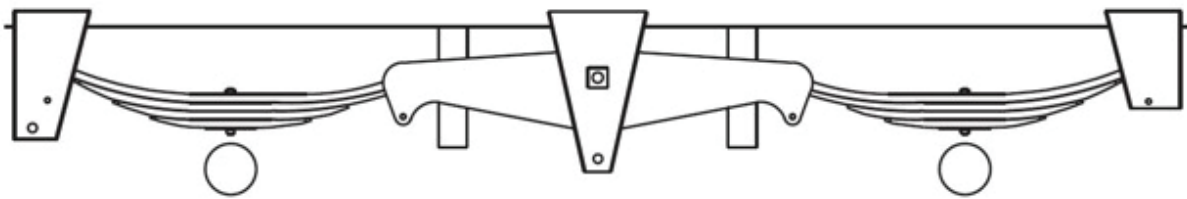

SPRING SUSPENSION

Figure 23

⚠ WARNING

Broken spring leaves, missing or loose U-bolts, or other defective conditions likely to cause axle shift, are hazardous and likely to cause accidents or breakdowns.

It is important that the spring, axle and spring seat are tightly clamped together. Movement can result in misalignment of the axle. Make sure that the U-bolts are regularly checked for tightness. Refer to the documentation of the original manufacturer of the suspension for proper torque.

AIR SUSPENSION

The air suspension height is controlled by a height control valve that maintains a constant semi-trailer height by pressurizing or exhausting air in the air springs as needed to support the load being carried.

You must build up and maintain your semi-trailer’s air pressure above 65 PSI before operating it. The air protection valve will not operate until you have 70 PSI in the system. This valve automatically maintains a safe air brake pressure higher than 70 PSI to compensate for air loss due to a failure in the suspension system.

⚠ CAUTION

- Do not operate the semi-trailer without air pressure in the air springs.
- A semi-trailer parked with a payload for any length of time and supported by the landing gear legs should be lowered on to the air spring internal bumpers.

SPRING SUSPENSION / AIR SUSPENSION

SUSPENSION INSPECTIONS

During regular semi-trailer maintenance, visually inspect the following components:

- All fasteners including the pivot bolts and U-bolts for security as applicable to your suspension.
- All welds, including axle connection pivot, beam, bracket and frame attachment.
- Structure: integrity of the semi-trailer frame, suspension beams and brackets.
- Broken or leaking shock absorbers.
- Air springs for chafing, rubbing, or damage.
- Air system valves, piping and fittings (refer to figure 24 below).
- Suspension ride height (refer to figure 25 below).

⚠WARNING

Do not use the semi-trailer if there is any damage to the suspension. Failure to follow these instructions can result in property damage, serious injury and death.

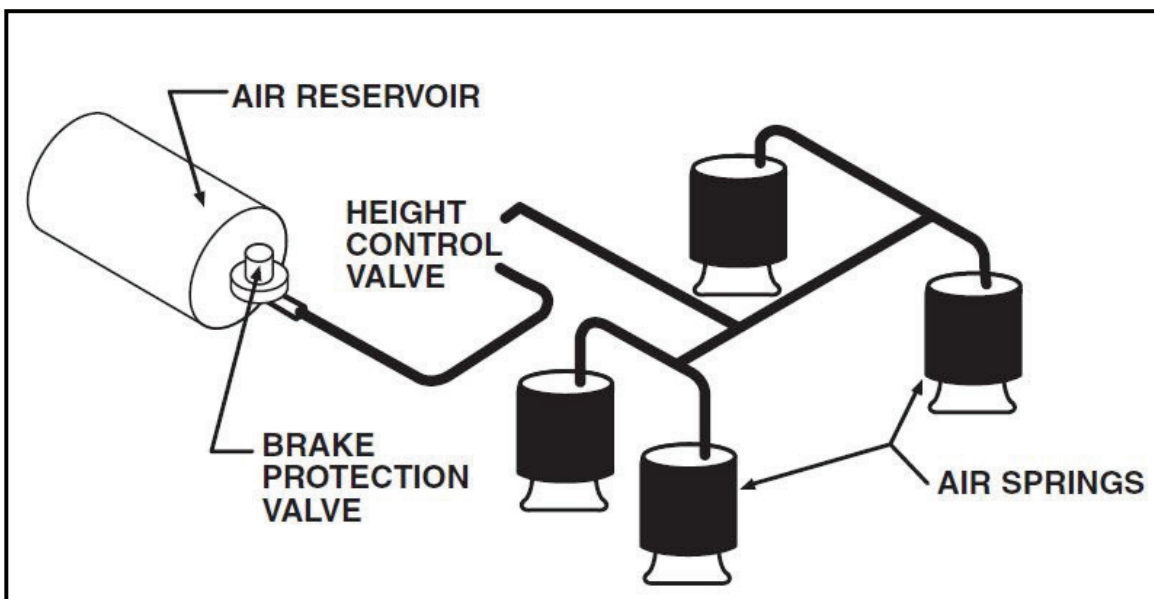

Figure 24

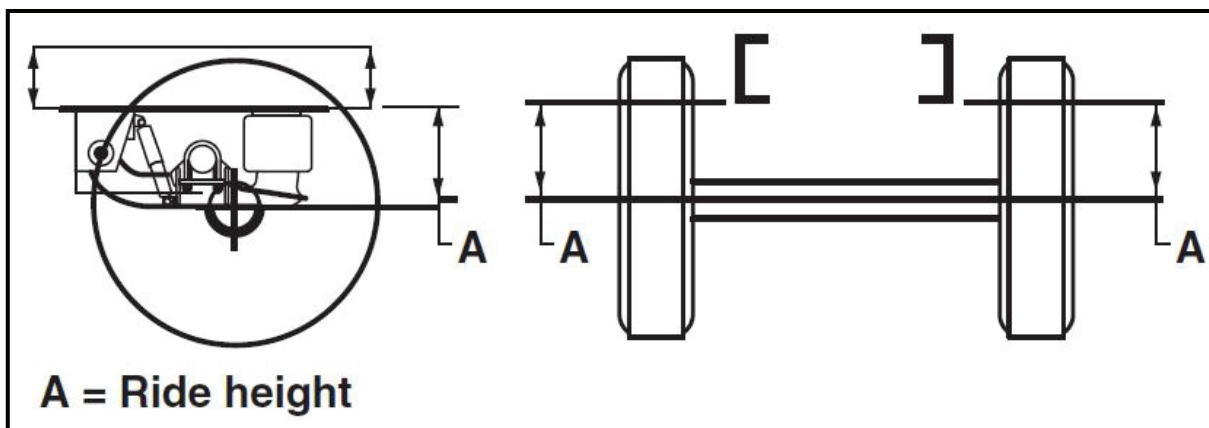

Figure 25

SPRING SUSPENSION / AIR SUSPENSION

Prior to Loading, Unloading or Prolonged Parking

DOCKING PROCESS

A - WITH Auto Reset

- Once the semi-trailer has been backed up to the loading dock, apply the semi-trailer's parking brakes.
- Manually activate the exhaust valve inside control box. Begin the loading/unloading process as usual.

B - WITHOUT Auto Reset

- Before backing up to the loading dock, manually activate the exhaust valve.
- Back the semi-trailer up to the loading dock, allowing the suspension to drain as you move backwards.
- Apply the semi-trailer's parking brakes after the air pressure has been completely drained. Chock the semi-trailer wheels and begin the loading/unloading process as usual.

If the semi-trailer is equipped with an automatic exhaust valve, the air in the suspension will be drained when the parking brakes are applied.

DRIVE-OUT PROCESS

- Couple the tractor and semi-trailer if needed.
- Raise the support legs, if needed, prior to inflating the suspension's air spring (bags).
- Activate the exhaust (dump) valve.
- Unchock the wheels, release the parking brakes and pull away from the loading dock after the semi-trailer reaches normal operating height.

NOTICE

1. If the semi-trailer is equipped with an auto-reset valve, air pressure in the bags will settle after taking off the parking brakes.
2. If the semi-trailer is equipped with an automatic exhaust valve, air pressure in the bags will settle after the parking brakes have been taken off.

LANDING GEAR OPERATION GUIDELINES

⚠WARNING

Do not attempt to lift or lower the semi-trailer with landing gear in high gear, as serious personal injury could occur.

Operation:

- The landing gear has two speeds: high and low. The high gear should be used to raise or lower the landing gear fast, when there is no weight on the support legs, while the low gear should be used when there is weight on the support legs.
- Lifting and lowering the semi-trailer must always be done in low gear and you must always raise landing gear completely before moving the semi-trailer.
- Pushing handle and crankshaft will engage high gear, while pulling it will engage low gear.
- Turning the handle clockwise will extend the support legs and turning counterclockwise will retract them.

Safety:

- The landing gear assembly is an important structural component and must be regularly inspected to ensure safe support of the trailer when it is not coupled.
- Only use the landing gear on a levelled, stable and solid ground.
- Always grip the crank handle securely with both hands.
- Maintain proper footing at all times and never attempt to shift the landing gear while under load.
- Always use chock blocks or lock semi-trailer brakes when uncoupling or coupling tractor and semi-trailer on the road or in the terminal area. Chock as required for unusual conditions.
- Always place sand shoes on a plank or smooth surface for flotation, to prevent sinking into soil or soft asphalt when a loaded semi-trailer is uncoupled from a tractor.
- Lower the support legs to the ground before uncoupling the trailer.
- Never leave the crank loose when moving. Store it in the crank holder.
- Maintain landing gear as per the recommendations of the original manufacturer.

NEVER force landing gear supports beyond their normal raised or lowered positions.

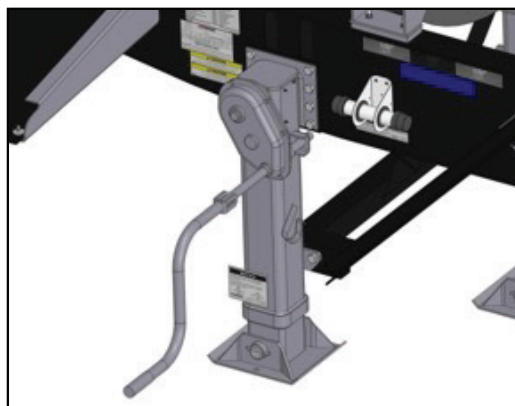

Figure 26

ELECTRICAL SYSTEM

The lights and the wiring system on every Manac Side Dump Semi-trailer meet or exceed all federal and state requirements in effect at the time of manufacture. Wherever required by law, lights and reflectors are marked by the manufacturer to indicate the appropriate specifications with which they comply.

For optimum performance and durability from the semi-trailer's lights and wiring, follow this inspection procedure:

- Clean all reflectors and lights. Check if all lights work properly. Replace all burnt-out lights and broken reflectors. Use factory approved replacement parts. The lights all have SAE classifications. A burnt out light must be replaced with a light of equivalent or higher SAE classification.
- Use only a 12-volt DC battery for checking lights or anti-lock systems.
- Inspect all wiring to ensure it is not frayed, and that it is properly supported and protected with all connections tight. Ensure that the light cable is clean and long enough to permit jack knife parking. Ensure that the cable is supported so that it cannot be pinched or entangled by the lower and upper couplers. Keep the 7-way plug on the light cable and the 7-way connector on the semi-trailer free of corrosion.
- Never replace fuses or breakers with metal foil or other metal objects.
- A decal is located on the front of each semi-trailer. You may trace individual electrical circuits with the wire colors indicated. Refer to the schematic drawing and the decal for conductor number and wire colors.

Usual electrical front plug configurations used by Manac

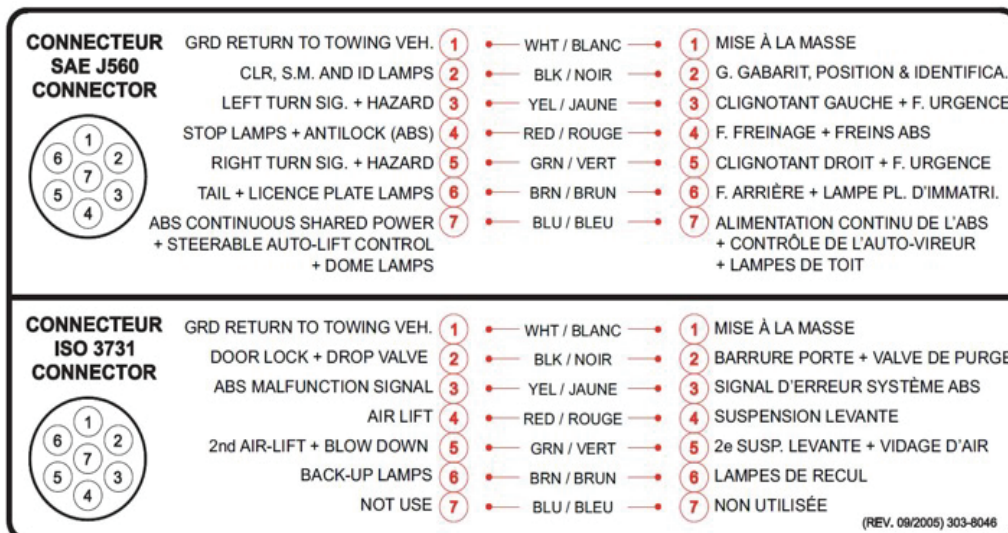

Figure 27

ELECTRICAL SYSTEM

TYPICAL WIRING DIAGRAM

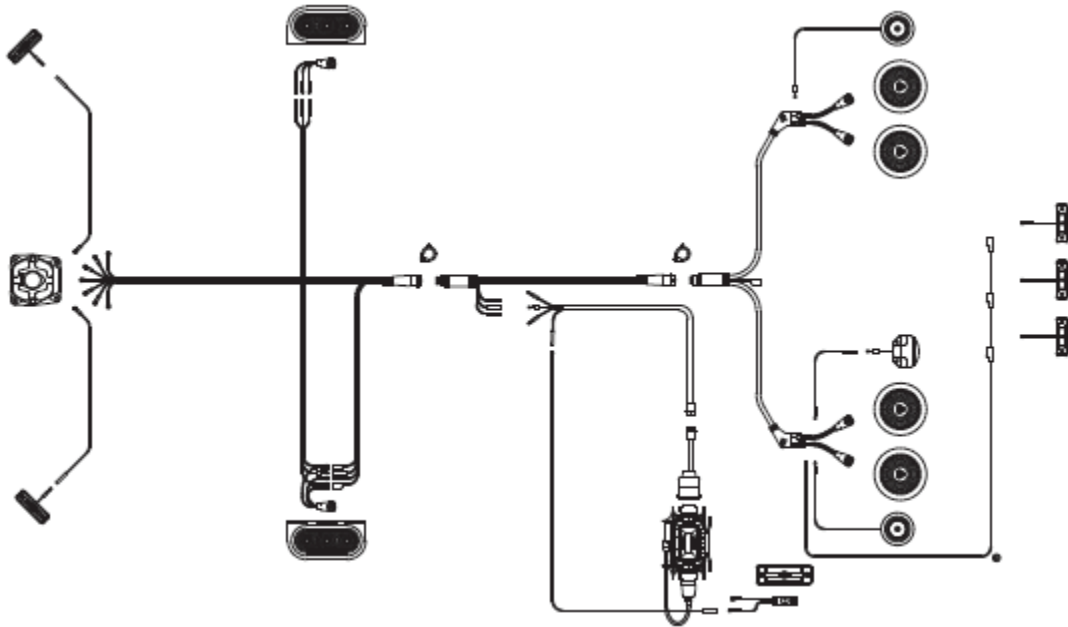

Figure 28



⚠ CAUTION

If the ABS indicator lamp comes on and stays on when you apply the brakes to a moving vehicle, the semi-trailer's ABS is not working properly. The ABS must be serviced as soon as possible upon completion of your trip to ensure full anti-lock braking capability.

TORQUE REQUIREMENTS

TORQUE SPECIFICATIONS

Tighten all bolts as per specified torque in Torque Table unless otherwise mentioned in other subsection of this manual. Always replace hardware with same grade and check tightness periodically.

Diamètre nominal / Nominal Dia. (po / in)	Nb filets au pouce / Threads per inch	Couple de serrage / Tightening Torque Boulons plaqués zinc / Zinc plated bolts Propre et sec / clean, dry threads (lb-pi / ft-lbs)*			
		Grade 2 	Grade 5 	Grade 8 	18-8 Stainless Steel Les marques varient selon le fabricant / Markings vary
Gros filets / Coarse Thread					
1/4	20	59 lb-po / in-lbs	91 lb-po / in-lbs	129 lb-po / in-lbs	81 lb-po / in-lbs
5/16	18	122 lb-po / in-lbs	188 lb-po / in-lbs	265 lb-po / in-lbs	168 lb-po / in-lbs
3/8	16	18	28	39	24
7/16	14	29	44	63	39
1/2	13	44	68	96	60
9/16	12	-	98	138	86
5/8	11	-	135	191	120
3/4	10	-	240	339	211
7/8	9	-	386	545	-
1	8	-	579	818	-
Filets fins / Fine Thread					
1/4	28	68 lb-po / in-lbs	104 lb-po / in-lbs	147 lb-po / in-lbs	92 lb-po / in-lbs
5/16	24	135 lb-po / in-lbs	208 lb-po / in-lbs	294 lb-po / in-lbs	183 lb-po / in-lbs
3/8	24	20	31	44	28
7/16	20	32	50	70	44
1/2	20	49	76	108	68
9/16	18	-	109	154	96
5/8	18	-	153	216	135
3/4	16	-	267	378	236
7/8	14	-	426	602	-
1	14	-	650	918	-

*La valeur de serrage pour les boulons 1/4 et 5/16 sont en livre-pouces. / Torque values for 1/4 and 5/16-inch series are in inch-pounds.

Figure 29

TORQUE REQUIREMENTS

Torque values in the torque table are valid only for non-greased and non-oiled hardware unless otherwise specified. Torque value should be increased by 5% from table value when using locking elements. Grade and class value of bolts and cap screw are identified by their head marking.

NOTICE

Torque is the tightening force applied to a bolt or nut. For example, a force of 80 pounds applied at the end of wrench of one foot long will yield 80 ft-lbs of torque.

Torque wrench must be used for tightening the fasteners to the proper torque.

⚠WARNING

Refer to the **Wheel Reinstallation and Nut Tightening section** of this manual for torque requirements and wheel installation and tightening procedure.

DECALS/REFLECTORS

IMPORTANT: Semi-trailer decals and reflectors must be kept in good condition. If a sticker is damaged, not readable, hidden or missing, replace it. If a part with a sticker is replaced, make sure to add the sticker on the replacement part. Decals and reflectors must never be removed from the semi-trailer, and painting over them is forbidden.

To order replacement stickers, reach out to Manac's after-sales service through this link: <https://parts.manac.com/>

The position of the decals on the semi-trailer is shown in the following figures. The associated Manac number of each decal is also shown below.

A list of all the stickers with their associated Manac number is available in appendix 1 attached to this manual.

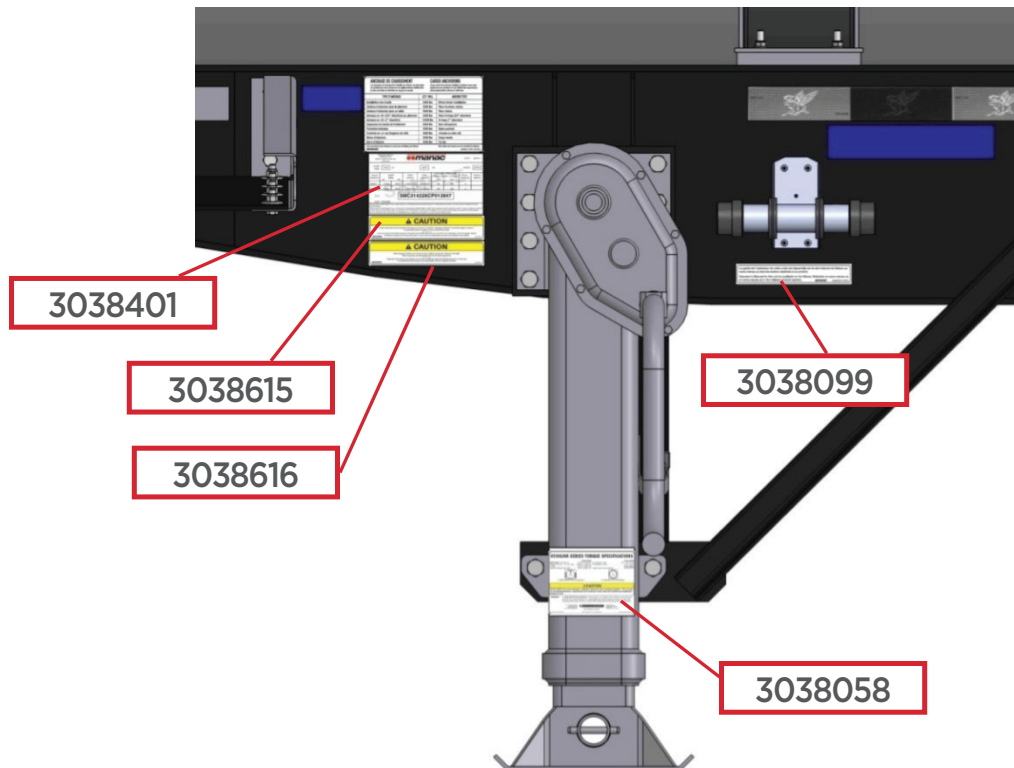

ROADSIDE / AHEAD OF LANDING GEAR - FIGURE 30

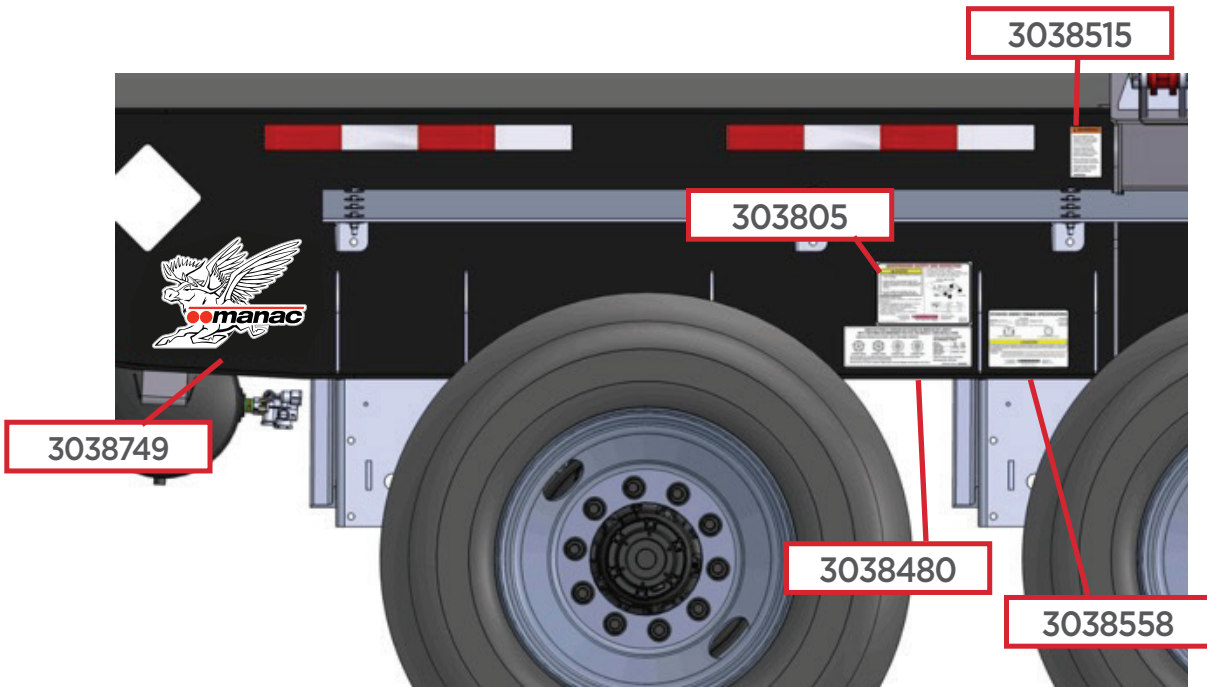

ROADSIDE / REAR BETWEEN AXLES - FIGURE 31

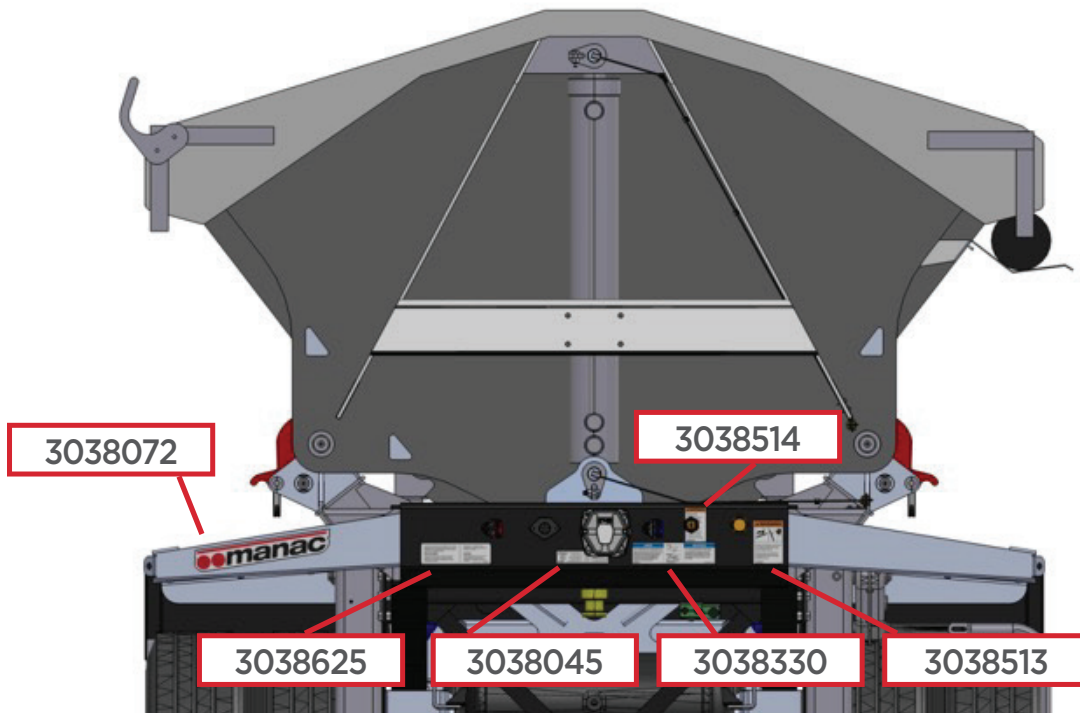

FRONT VIEW - FIGURE 32

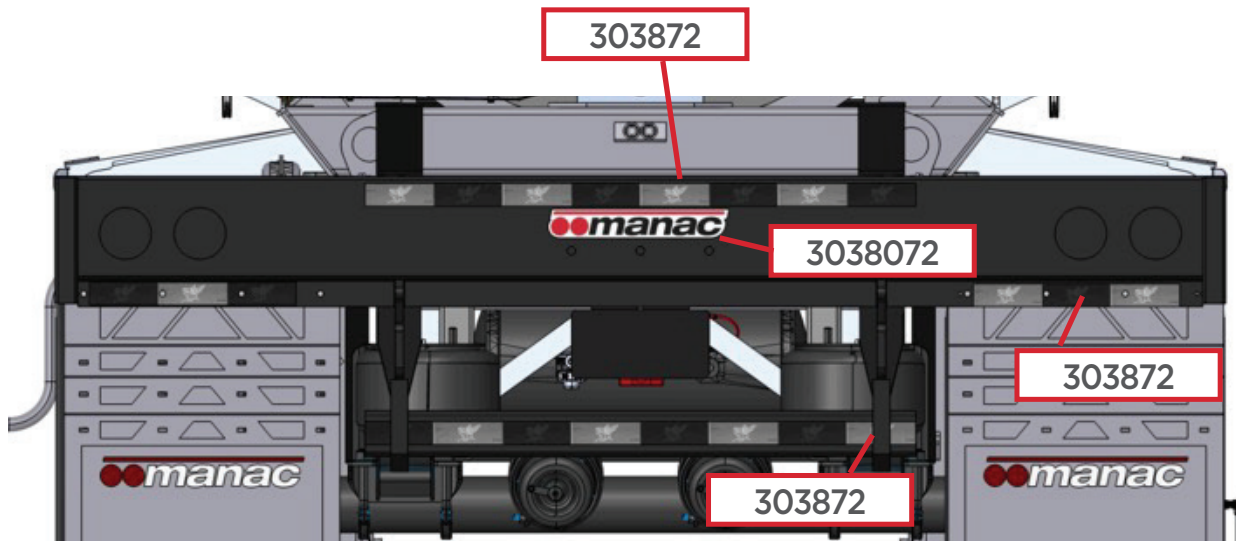

REAR BUMPER - FIGURE 33



ROADSIDE VIEW / FRONT - FIGURE 34

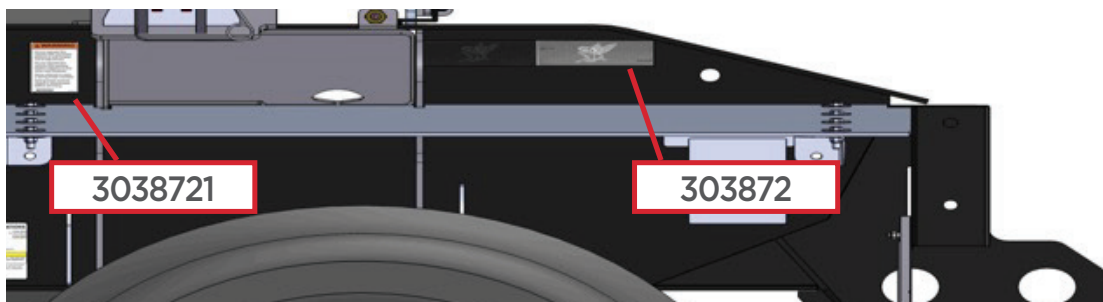

ROADSIDE VIEW / OVER TIRE REAR - FIGURE 35

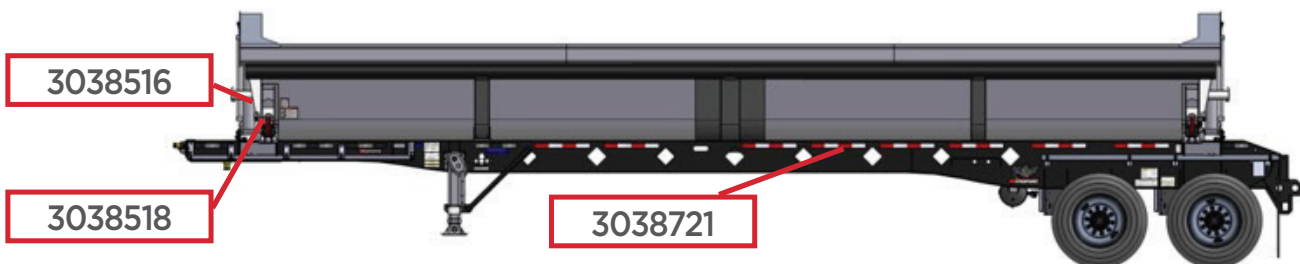

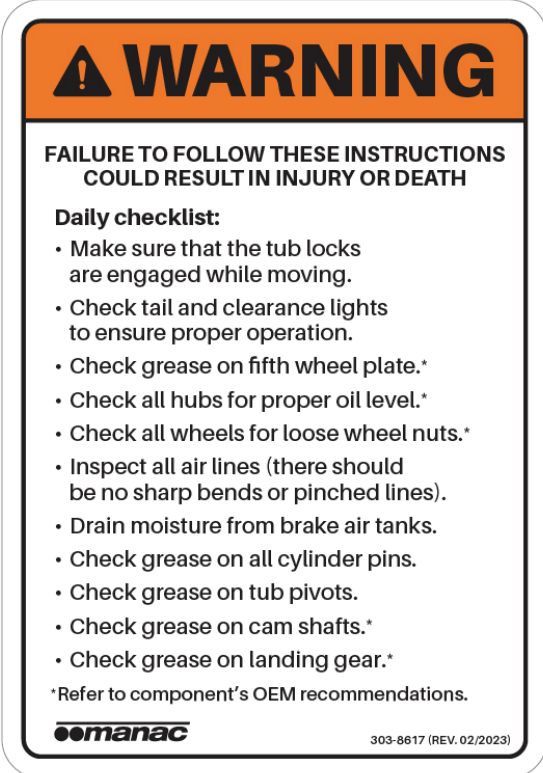
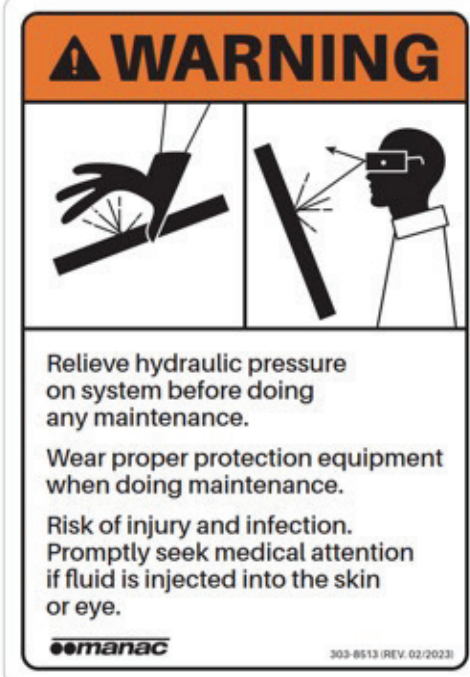

FIGURE 36

APPENDIX I: DECALS / REFLECTORS

MANAC NUMBER	STICKER
303-8615	 <p>⚠ WARNING / AVERTISSEMENT</p> <p>Trailer decals and reflectors must be kept in good condition. If a sticker is damaged, blocked or becomes illegible, replace it. If a part with a sticker is replaced, be sure to add the sticker. Failure to follow these instructions could result in injury or death.</p> <p>Les autocollants et les réflecteurs de la remorque doivent être maintenus en bon état. Si un autocollant est endommagé, obstrué ou illisible, remplacez-le. Si une pièce avec un autocollant est remplacée, assurez-vous d'ajouter l'autocollant.</p> <p>manac Le non-respect de ces instructions peut entraîner des blessures ou la mort. 303-8615 (REV. 02/2023)</p>
303-8616	 <p>⚠ WARNING / AVERTISSEMENT</p> <p>Trailer operator should do an annual review of safety regulations relating to the trailer. Trailer's operator must be familiar with these safety regulations. Failure to follow these instructions could result in injury or death.</p> <p>L'opérateur de remorque devrait faire une revue annuelle des règles de sécurité relatives à la remorque. Le conducteur de la remorque doit être familier avec ces règles de sécurité.</p> <p>manac Le non-respect de ces instructions peut entraîner des blessures ou la mort. 303-8616 (REV. 02/2023)</p>
303-8617	 <p>⚠ WARNING</p> <p>FAILURE TO FOLLOW THESE INSTRUCTIONS COULD RESULT IN INJURY OR DEATH</p> <p>Daily checklist:</p> <ul style="list-style-type: none"> • Make sure that the tub locks are engaged while moving. • Check tail and clearance lights to ensure proper operation. • Check grease on fifth wheel plate.* • Check all hubs for proper oil level.* • Check all wheels for loose wheel nuts.* • Inspect all air lines (there should be no sharp bends or pinched lines). • Drain moisture from brake air tanks. • Check grease on all cylinder pins. • Check grease on tub pivots. • Check grease on cam shafts.* • Check grease on landing gear.* <p>*Refer to component's OEM recommendations.</p> <p>manac 303-8617 (REV. 02/2023)</p>

303-8513



⚠ WARNING

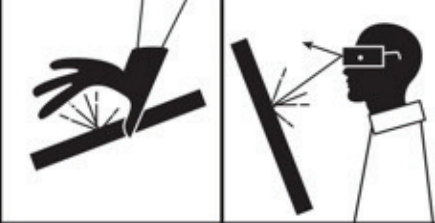

Relieve hydraulic pressure on system before doing any maintenance.

Wear proper protection equipment when doing maintenance.

Risk of injury and infection. Promptly seek medical attention if fluid is injected into the skin or eye.

manac 303-8513 (REV. 02/2023)

303-8514

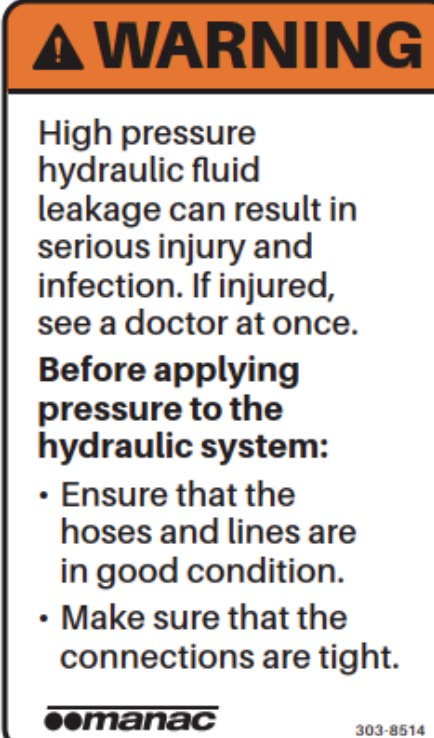

⚠ WARNING

High pressure hydraulic fluid leakage can result in serious injury and infection. If injured, see a doctor at once.

Before applying pressure to the hydraulic system:

- Ensure that the hoses and lines are in good condition.
- Make sure that the connections are tight.

manac 303-8514

303-8515

⚠ WARNING

Do not operate this vehicle with any brake defects or with brakes out of adjustment.

Do not operate this vehicle with parking brakes caged or in any other way disabled.

Never attempt to open a spring break chamber.

Spring break must be caged or deactivated before servicing.

Failure to follow these instructions could result in injury or death.

manac 303-8515 (REV. 02/2023)

303-8516

⚠ DANGER

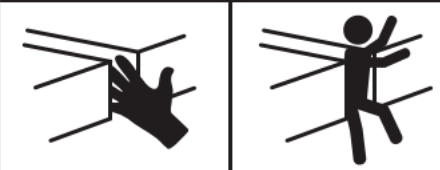

PINCH POINT HAZARD

To prevent serious injury or death from pinching:

1. Exhaust air from the system prior to maintenance.
2. Keep clear from pinch points.

manac 303-8516

303-8517

⚠ WARNING/AVERTISSEMENT

FALL HAZARD/RISQUE DE CHUTE

DO NOT climb into the trailer body. Use extreme caution when climbing on ladders, steps and catwalks. Always maintain 3-point contact when climbing on and off equipment. Failure to follow these instructions could result in injury or death.

NE PAS grimper dans la remorque. Faites preuve de grande prudence en grimpant sur une échelle, des marches ou une passerelle. Maintenez toujours 3 points de contact lorsque vous grimpez sur un équipement. Le non-respect de ces instructions peut entraîner des blessures ou la mort.

manac

303-8517 (REV. 02/2023)

303-8518

⚠ DANGER

To avoid severe injury, death and trailer damage when dumping on this side:

- Close, lock and secure pivot lock with pin through bracket.
- Make sure that the locks on the opposite side are opened.

Before dumping:



- Do not attempt to dump load on uneven or unstable ground.
- Truck and trailer wheels must be in a straight line.
- Make sure that there are no overhead hazard or power lines.
- Clear the area around semi-trailer of vehicles, objects of any kind and bystanders.
- Air suspension must be fully charged.
- Do not attempt to dump a frozen load.

While dumping:

- Stand clear of tub body.
- Stand clear of load.
- Operator must remain at controls until cylinders are fully retracted.
- Do not stop the cylinder extension at any point during the extension cycle.

manac

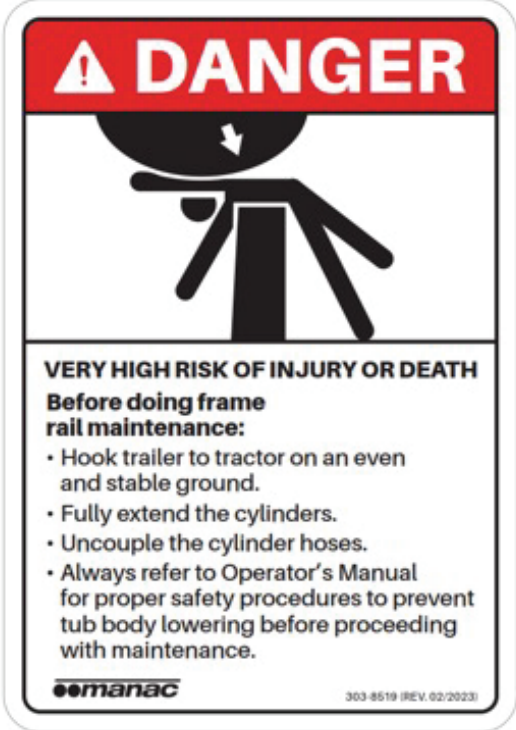
303-8518 (REV. 02/2024)

<p>303-8519</p>	 <p>VERY HIGH RISK OF INJURY OR DEATH Before doing frame rail maintenance:</p> <ul style="list-style-type: none"> • Hook trailer to tractor on an even and stable ground. • Fully extend the cylinders. • Uncouple the cylinder hoses. • Always refer to Operator's Manual for proper safety procedures to prevent tub body lowering before proceeding with maintenance. <p>manac 303-8519 (REV. 02/2023)</p>
<p>303-8618</p>	 <p>CAUTION</p> <p>Grease tub pivots daily.</p> <p>manac 303-8618 (REV. 02/2023)</p>
<p>303-8619</p>	 <p>CAUTION</p> <p>Parking procedure:</p> <ul style="list-style-type: none"> • Park on stable and even ground. • Fully retract cylinders. • Exhaust air from suspension. • Lower support legs to the ground. • Disconnect air, electrical and hydraulic. • Remove tub drain plug, if trailer is parked for a long time. <p>manac 303-8619 (REV. 02/2023)</p>

303-8072



303-8045

AVIS <i>i</i> NOTICE	CONNECTEUR SAE J560 SAE J560 CONNECTOR		GRD RETURN TO TOWING VEH. ① CLR, S.M. AND ID LAMPS ② LEFT TURN SIG. + HAZARD ③ STOP LAMPS + ANTILOCK (ABS) ④ RIGHT TURN SIG. + HAZARD ⑤ TAIL + LICENCE PLATE LAMPS ⑥ ABS CONTINUOUS SHARED POWER ⑦	← WHT / BLANC → ① ← BLK / NOIR → ② ← YEL / JAUNE → ③ ← RED / ROUGE → ④ ← GRN / VERT → ⑤ ← BRN / BRUN → ⑥ ← BLU / BLEU → ⑦	① MISE À LA MASSE ② F. GABARIT, POSITION & IDENTIFICA. ③ CLIGNOTANT GAUCHE + F. URGENCE ④ F. FREINAGE + FREINS ABS ⑤ CLIGNOTANT DROIT + F. URGENCE ⑥ F. ARRIÈRE + LAMPE PL. D'IMMATRI. ⑦ ALIMENTATION CONTINUE DE L'ABS
--	---	--	--	---	---

303-8330

AVIS	Correct Incorrect Hauteur de portée (H) Ride height (H)	NOTICE
Pour éviter le bris d'équipement. Cette semi-remorque est dotée d'un train de suspension pneumatique. Par conséquent, le fabricant interdit le déplacement de la semi-remorque si les ballons de suspension ne sont pas gonflés à leur hauteur de portée appropriée.		To avoid equipment damage. This semitrailer is equipped with an air suspension. Consequently, it is strictly prohibited by the manufacturer to move the semitrailer without the appropriate ride height.

303-8625

⚠ AVERTISSEMENT / WARNING ⚠	
Risque important de blessure ou de mort Cette semi-remorque est équipée d'un circuit pneumatique de freinage conforme à la norme CMVSS 121 donnant priorité au relâchement des freins de stationnement. Cette semi-remorque ne devrait pas être déplacée avant que la pression dans les réservoirs du système n'atteigne la valeur minimale de 90 psi.	Significant risk of injury or death This trailer is equipped with a CMVSS 121 conform spring brake priority air system. This trailer should not be moved before system reservoirs are charged to a minimum pressure of 90 psi.

303-8749

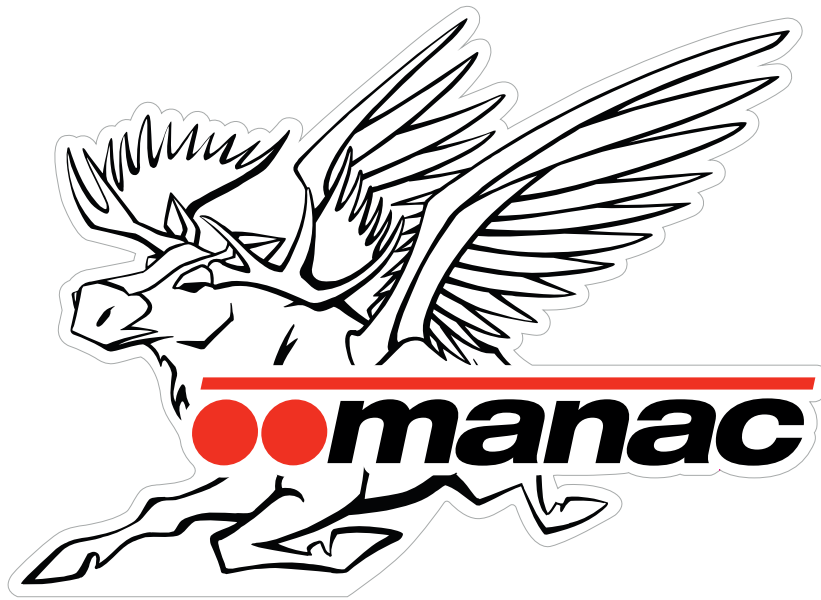

303-8480

<p>COUPLE DE SERRAGE REQUIS/ RECOMMENDED TORQUE 450-500 FT. LBS.</p> <p><small>*(huilé/oiled)</small></p> <div style="display: flex; justify-content: space-around;"> <div style="text-align: center;"> <p>8 ÉCROUS/ NUTS</p> </div> <div style="text-align: center;"> <p>10 ÉCROUS/ NUTS</p> </div> </div> <p>ORDRE DE SERRAGE/ NUTS TIGHTENING SEQUENCE</p> <p><small>manac</small></p>	<p>⚠ AVERTISSEMENT</p> <p>DIRECTIVES DE SERRAGE DES ÉCROUS DE ROUE (s'applique aux écrous M22x1.5 / écrou à bride deux pièces) :</p> <ul style="list-style-type: none"> • Vérifiez que les roues à disque sont bien positionnées sur les butées de centrage et bien assises contre la face du moyeu. • Serrez initialement les écrous de roue à 50 lbs-pi en suivant la séquence indiquée. • Serrez les écrous de roue à une valeur finale entre 450 et 500 lbs-pi (huile) en suivant la séquence indiquée. <div style="border: 1px solid black; padding: 5px; margin-top: 5px;"> <ul style="list-style-type: none"> • Après les premiers 50 à 100 miles d'opération, revérifiez les valeurs de serrage. Une réduction du serrage peut causer le bris ou la perte des jantes. • Vérifier le serrage à chaque 10 000 miles. </div> <p><small>Lors d'une réinstallation, ajoutez deux gouttes d'huile de grade 30 à un point entre les deux pièces des écrous à bride et deux gouttes aux deux à trois derniers filets à l'extrémité de chaque goujon. Ne pas appliquer de lubrifiant sur la face du tambour ou de la roue.</small></p>
	<p>⚠ WARNING</p> <p>WHEEL NUT TIGHTENING RECOMMENDED PRACTICE (applies to M22x1.5 / two-piece flange nut):</p> <ul style="list-style-type: none"> • Check disc wheels for proper positioning on drum pilot and proper seating against hub face. • Tighten flange nuts to 50 ft.lb using sequence shown. • Tighten wheel nuts to a final torque between 450 to 500 lbs ft.lb (oiled), using the sequence shown <div style="border: 1px solid black; padding: 5px; margin-top: 5px;"> <ul style="list-style-type: none"> • Recheck torque after the first 50 to 100 miles of service. A drop of torque may result in damage or loss of wheels. • Recheck torque every 10,000 miles. </div> <p><small>On a re-installation, add two drops of 30 weight oil to a point between the two pieces of the flange nuts and two drops to the last two or three threads at the end of each stud. Do not get lubricant on the mounting face of the drum or wheel.</small></p> <p style="text-align: right;"><small>303 8480 (REV. 02/2023)</small></p>

303-8558

HT/HS/HK SERIES TORQUE SPECIFICATIONS

ft. lbs. (N•m)		ft. lbs. (N•m)	
QUIK-ALIGN® Pivot Bolt (1).....	550±45 (750±50)	Air Spring Nut, Upper.....	90±10 (125±10)
Welded Pivot Bolt (1.25" Dia.) (2).....	800±25 (1085±30)	Air Spring Nut, Lower.....	45±5 (61±6)
U-Bolts.....	500±25 (680±30)		in. lbs. (N•m)
Shock Bolt (Upper and Lower).....	225±10 (300±10)	Height Control Valve Mounting.....	70±10 (8±1)

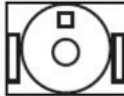

1) QUIK-ALIGN Pivot Connection

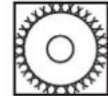

2) Welded Pivot Connection

⚠ CAUTION

DO NOT APPLY anti-seize compound or additional lubricant to pivot connection hardware. This can lead to overtightened fasteners, unpredictable pivot connection clamp loads and unreliable axle alignments. Reference L579.

IMPORTANT: For QUIK-ALIGN® pivot connections, a torque wrench is not required when installing a new shear-head pivot bolt and a prevailing-torque nut. During tightening, the bolt's shear-head feature will shear after achieving proper torque. Use two (S-24679) QUIK-ALIGN pivot bolt kits per axle during a realignment.

Tadler Commercial Vehicle Systems
2270 Industrial Plaza SE
Canton, OH 44707-2641 USA
866.963.8627 (743-3247)
230.489.0045 • FAX 900.1986.4410

H HENDRICKSON
www.hendrickson-intl.com

Hendrickson Canada
250 Chrysler Drive, Unit #13
Brampton, ON Canada L6S 6B6
905.508.5380
905.789.1030 • FAX 905.789.1033

L336 Rev K 02-16 IEN 23618 ©2015 Hendrickson USA, L.L.C. All Rights Reserved Printed in United States of America

303-8058

NOTICE

ALWAYS use low gear when landing gear is touching the ground. Push crank handle in for low gear.

Utiliser toujours la petite vitesse lorsque la béquille touche le sol. Pousser la manivelle pour la petite vitesse.

↻

Raise Trailer
Lever La Remorque

↻

Lower Trailer
Abaisser La Remorque

SAF-HOLLAND
Copyright © 2015 - SAF-HOLLAND™, Inc

ATLAS 55 and ATLAS 65 Inside Mount/Montage intérieur
MARK V, Fast Gear and Fast Gear HD Outside Mount/Montage extérieur
www.safholland.us

XL-LG362-EF Rev C

303-8099

Le manuel de l'opérateur de cette unité est disponible sur le site internet de Manac au www.manac.com.

The operator's manual for this unit is available on the Manac website at www.manac.com.

manac 3038099 (REV. 11/2021)

APPENDIX II: TROUBLESHOOTING

PROBLEM	CAUSE	SOLUTION
Complete loss of trailer light	<ul style="list-style-type: none"> • Broken main harness • Light switch on towing vehicle malfunctioning • Current is not flowing from towing vehicle • Frayed wires • Lost or corroded connection in ground lead between tractor and trailer • Dirty or corroded contacts in connectors of semi-trailer wiring • Junction box failure 	<ul style="list-style-type: none"> • Repair or replace • Check light switch • Inspect circuit breaker and wiring on towing vehicle • Repair as required • Repair or replace • Clean corroded contacts in connectors • Replace junction box
Lights flicker or don't come on	<ul style="list-style-type: none"> • Damaged or disconnected wire on ground cable • Bad and broken connection • Battery on tractor not sufficiently charged • Poor ground at sockets 	<ul style="list-style-type: none"> • Repair or replace cable as required • Check electrical system circuits • Charge battery • Repair as necessary
Individual lamps don't light or flash improperly	<ul style="list-style-type: none"> • Internal short in junction box • Bad or loose connection • Damaged light assembly • Corroded lamp socket 	<ul style="list-style-type: none"> • Replace junction box • Check cables for brakes and bad connections. Tighten, repair, or replace. Clean connections • Repair or replace light assembly • Remove lamp and clean contacts
Lights flash improperly or appear to be crossed	<ul style="list-style-type: none"> • Dirty or corroded contact in receptacle or on plug of inter vehicular cable • Internal short in junction box 	<ul style="list-style-type: none"> • Clean receptacle and plug • Replace junction box

PROBLEM	CAUSE	SOLUTION
<p>High or uneven tire wear</p>	<ul style="list-style-type: none"> • Over or under inflation • Loose wheel stud nuts or clamps. • Rapid stopping • Axle bent or out of alignment • Loose or tight wheel bearing 	<ul style="list-style-type: none"> • Inflate to proper pressure. • Tighten wheel stud nuts or clamps. • Apply brakes slowly when approaching stops. • Straighten, align, or replace axle. • Adjust bearing
<p>Wobbly tires</p>	<ul style="list-style-type: none"> • Worn or damaged wheel bearings • Tire wobble due to uneven rim clamping. 	<ul style="list-style-type: none"> • Replace bearings • Torque tighten all rim clamps.
<p>Loss of tires air pressure</p>	<ul style="list-style-type: none"> • Puncture in tire • Wheel or rim damage • Faulty valve or valve core 	<ul style="list-style-type: none"> • Repair or Replace tire • Replace wheel or rim • Replace Valve assembly or core
<p>Excessive compressor cycling</p>	<ul style="list-style-type: none"> • Air leak 	<ul style="list-style-type: none"> • Check air in fittings and hose connections on service or supply line. • Check service chamber at clamp housing, push rod for damage. • Check service chamber diaphragm. • Check emergency chamber clamp and vent holes for leakage.

PROBLEM	CAUSE	SOLUTION
<p>Trailer brakes slow and sluggish</p>	<ul style="list-style-type: none"> • System or component failure 	<ul style="list-style-type: none"> • Check slack adjuster and chamber/spring brake push rod alignment for interference. • Assure open lines-no kinks, bends, closed shut-off cocks, restrictions, excessive elbows... • Assure adequate tractor brake function.
<p>Poor braking performance</p>	<ul style="list-style-type: none"> • Full function valve (FFV) leaks at exhaust port with all brakes released. • Full function valve (FFV) leaks at exhaust port with service brakes applied. • Spring parking brake (service only service chamber side of spring brake) drags or won't release. • Trailer brake lining wear excessive • Trailer brakes slow to apply. 	<ul style="list-style-type: none"> • Replace FFV valve • Replace FFV valve • Check for: <ul style="list-style-type: none"> - Improper adjustment, restriction, or broken line. - Diaphragm failure. - Broken power spring. - Replace entire unit or piggy-back emergency section. - System pressure too low (120 psi min.) • Have authorized service centre check for adequate pressure and timing balance relative to tractor/trailer application. • Check slack adjuster and chamber/spring brake push rod angle 90° applied with proper adjustment. • Check air delivery to all reservoirs at system working pressure. • Check functional return spring in service chamber or spring brake.

APPENDIX III: CONNECTOR WIRING CHANGE

NOTICE FOR ALL TRACTOR-SEMI-TRAILER OWNERS AND USERS.

Federal Motor Vehicle Safety Standard No. 121, Air Brake Systems, was amended by the National Highway Traffic Safety Administration of DOT requiring that truck tractors manufactured on/or after March 1, 1997, provide constant power for a semi-trailer's antilock brake system (ABS). Some manufacturers will provide this feature prior to the effective date. These tractors using a single 7-way electrical connector will have constant power for ABS on the centre pin when the key switch is on. Tractor-semi-trailer owners and users who presently use the centre pin for auxiliary power for equipment other than semi-trailer ABS (for example: dome lights, backing lights, bottom dumps, sliding undercarriages, air ride dump valves, etc.) will be affected by this change. In certain uses of this constantly powered centre pin connector, unexpected or unintended activation of this equipment may be hazardous or result in personal injury. Before connecting your semi-trailer to a tractor, make sure that the constantly powered centre pin will not unintentionally turn on semi-trailer equipment. If you have any questions about your present wiring, or how to rewire your vehicles, you should contact the tractor supplier and/or MANAC Customer Service Department.



8593 State Highway 77
P.O. Drawer K
Oran MO 63771 USA
Toll free : 1 800 545-5086
T.: 573 262-2166

SIDE DUMP OPERATOR MANUAL

